

# Scotsman® MAR125



- MAR55
- MAR75
- MAR105
- MAR125**
- MAR205
- MAR305



MAR 125 AS



Adjustable Thickness  
1mm or 2 mm  
3/76" or 3/38"

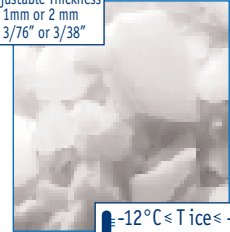

-12°C ≤ T ice ≤ -6°C  
10°F ≤ T ice ≤ 21°F

## SCALE ICE

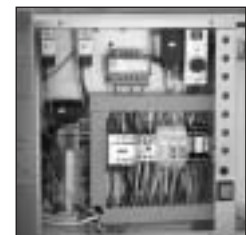
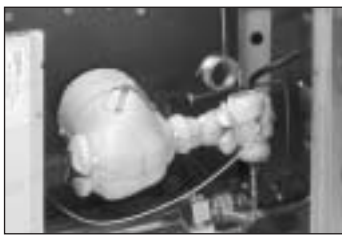

Scale Ice  
Maker  
Units

Unités de  
Production  
de Glace  
en Ecailles

Scherbeneis-  
Produktions-  
einheit

Fabricador  
de Hielo  
en Escamas

Unità di  
Produzione  
Ghiaccio  
in Scaglie

		24h		THICK ICE		NOMINAL ONLY		[V/Hz/ph]	[WxDxH mm]	[HxWxD inches]	R 404 A
		± 2 mm [kg] [lbs]	± 0,5 mm [kg] [lbs]								
MAR 125 AS		1000	2200	1450	3190	400/50/3N	906x813x1125	35 11/16" x 32" x 44 5/16"	R 404 A		
MAR 125 WS		1000	2200	1450	3190	400/50/3N	906x813x1125	35 11/16" x 32" x 44 5/16"	R 404 A		
MAR 125 WS SW		1000	2000	1450	3190	400/50/3N	906x813x1125	35 11/16" x 32" x 44 5/16"	R 404 A		

Options (to be ordered separately):  
Stainless steel panels (for refrigeration system section)

**2**

Years Warranty  
Ans de Garantie  
Jahre Garantie  
Años de Garantía  
Anni di Garanzia

Subject to certain limitations and exclusions  
Assujettie aux limites et exclusions prescrites  
Abhängig von Bestimmten Einschränkungen und Ausnahmen  
Sujeta a algunas limitaciones y exclusiones.  
Soggetta ad alcune limitazioni ed esclusioni



This product qualifies for the following listings:

Models and specifications are subject to change without notice - Les modes et les caractéristiques des appareils peuvent être changés sans préavis - Wir behalten das Recht vor jederzeit Änderungen der Modelle und der technischen Angaben vorzunehmen. Los modelos y las características pueden ser modificados en cualquier momento sin previo aviso - I modelli e le specifiche possono essere cambiate in qualunque momento senza preavviso

# MAR125

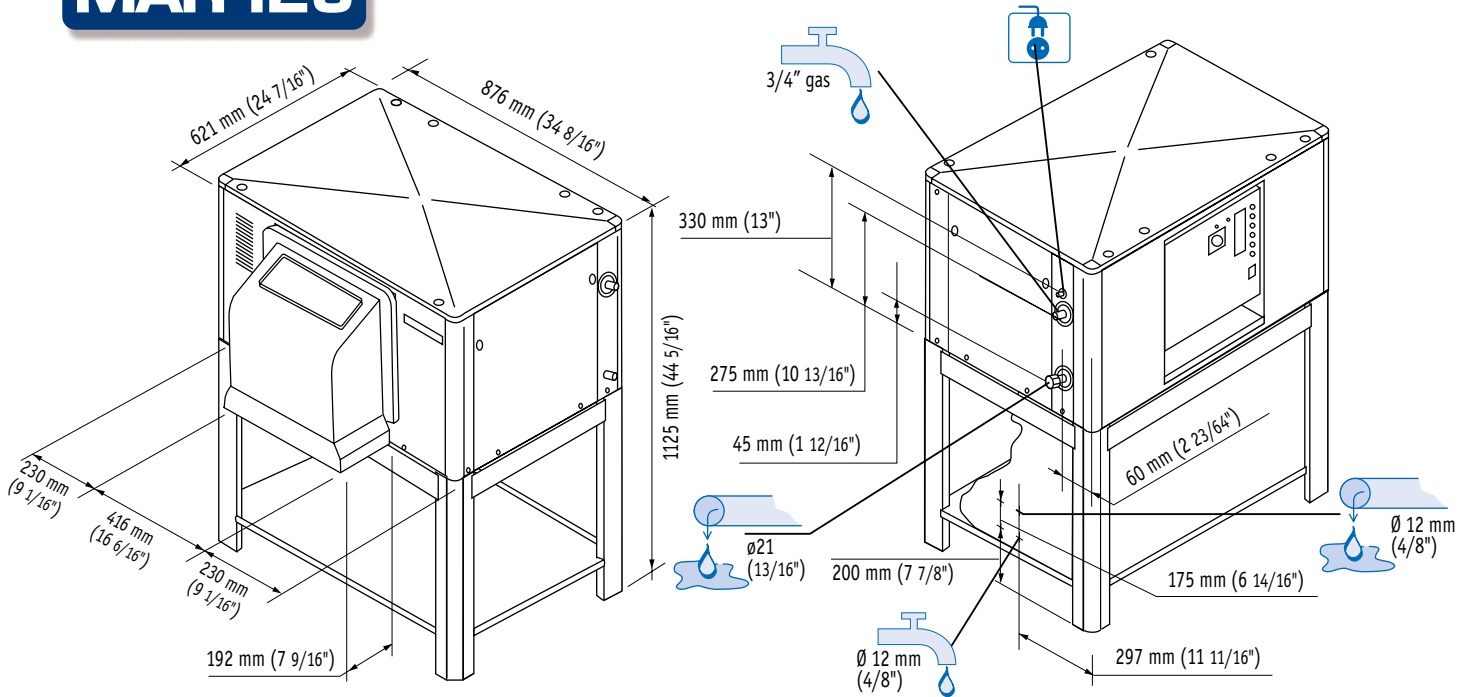

	+C° -C°	(T cond.+54,5°C/T evap. -23,3°C) [W] [Btu/h]	[S mm <sup>2</sup> ] [AWG]	[W]	FUSE	[kWh] 24h	[L/h] 32°C 90°F 21°C 70°F	[gal/h]	[kg] [lb]	[kg] [lb]	[kg] [lb]	[kg] [lb]
MAR 125 AS		5455 18600	5 x 1,5 AWG 15	4500	16A	108	32.5 8	209 460	226 498			
MAR 125 WS		5455 18600	5 x 1,5 AWG 15	4500	16A	108	n.a. n.a.	205 452	222 489			
MAR 125 WS SW		5455 18600	5 x 1,5 AWG 15	4500	16A	108	n.a. n.a.	205 452	222 489			

## MAR 125 AS



°F	50°	60°	70°	90°	
°C	10°	15°	21°	32°	
10°	1000	980	960	920	kg
50°	2205	2161	2117	2029	lbs
21°	920	900	880	840	kg
70°	2029	1985	1940	1852	lbs
32°	820	800	780	740	kg
90°	1808	1764	1720	1632	lbs
38°	720	700	680	640	kg
100	1588	1544	1499	1411	lbs



## MAR 125 WS



°F	50°	60°	70°	90°	
°C	10°	15°	21°	32°	
10°	n.a.	n.a.	n.a.	n.a.	kg
50°	n.a.	n.a.	n.a.	n.a.	lbs



### Minimum

10°C (50°F)

5°C (41°F)

-10%

1 BAR

14 psi



### Maximum

40°C (104°F)

35°C (95°F)

+10%

5 BAR

70 psi

Machine requires voltage indicated on rating name plate. Failures caused by improper voltage are not considered factory defects. Scotsman products are not designed for outdoor installation. Extended periods of operation at temperatures exceeding the above limitations constitutes misuse under the terms of Scotsman Limited Warranty, resulting in a loss.

La machine doit être raccordée conformément au voltage indiqué sur la plaque signalétique. Les éventuels dégâts causés par un non respect de cette consigne ne peuvent être considérés comme des défauts de fabrication. Les machines à glace Scotsman ne sont pas conçues pour être utilisées à l'extérieur. Le fonctionnement prolongé à des températures supérieures ou inférieures aux limites ci-dessus sont considérées comme une mauvaise utilisation dans le cadre de la garantie Scotsman.

Der Eisbereiter benötigt eine Stromspannung gemäß Geräte-Typenschild. Störungen oder Ausfälle, durch den Betrieb mit falscher Stromspannung sind keine Fabrikationsfehler und fallen nicht unter Garantie. Scotsman Eisbereiter sind nicht für die Installation im Freien geeignet. Der längere Betrieb bei Temperaturen über den obigen Grenzwerten ist eine falsche Anwendung und bedeutet den Verlust der Garantieleistung.

Los requerimientos eléctricos de la máquina están indicados en la placa de características. Los daños causados por voltajes inadecuados no son considerados defectos de fábrica. La máquina de hielo Scotsman, no están diseñadas para trabajar a la intemperie. Largos periodos de funcionamiento a temperaturas que excedan de las limitaciones indicadas, constituyen maltrato de acuerdo con las observaciones de Scotsman.

La macchina richiede il voltaggio indicato sulla targhetta di identificazione. Danni causati da voltaggi diversi non sono considerati difetti di produzione. I prodotti Scotsman non vanno utilizzati all'aperto. Un prolungato periodo di utilizzo al di fuori delle temperature indicate non è consentito e causa l'automatico decadere della garanzia.



**Scotsman**<sup>®</sup>  
Ice Systems

The one the world relies on.

Certified ISO 9001:2000

### USA, Canada, Latin America

Scotsman Ice Systems USA  
775 Corporate Woods Parkway  
Vernon Hills, IL 60061  
Ph: (+1) 847 215-4550  
Fax (+1) 847 913-9844  
customer.service@scotsman-ice.com

### Europe

Scotsman Europe-Frimont S.p.A.  
Via Puccini, 22  
20010 Pogliano (Milano) Italy  
Ph: (+39) 02-93960208  
Fax: (+39) 02-93960201  
scotsman.europe@frimont.it

### Asia and Pacific

Scotsman Ice Systems-Frimont S.p.A. (R.O.)  
627A Aljunied Road #04-04 Biztech Centre  
Singapore 389842  
Ph: (+65) 6738 5393  
Fax: (+65) 6738 1959  
scotsice@singnet.com.sg

### China

Scotsman Ice Systems  
258 Tong Ren Road Golden Tower 7A  
Shanghai-200040 Peoples's Republic of China  
Ph: (+86) 21-62476056  
Fax: (+86) 21-62476126  
scotsmarsh@online.sh.cn

### Middle East & N. Africa

Scotsman Ice Systems Dubai Office  
P.o. Box 21648  
Sharjah - U.A.E.  
Mobile: Ph: (+971) 505505980  
Fax (+971) 6-5654063  
scotsman@eim.ae

### South Africa

Scotsman Ice Systems SA (PTY) Ltd.  
10, Rhodes Street - Kensington B  
P.o. Box 44 - Riverclub 2149  
Ph: (+27) 11-7898400  
Fax (+27) 11-7898411  
scotsman@telkomsa.net