

®

SCOOTSMAN

SERVICE MANUAL

EC 45

EC 55

EC 85

EC 105

EC 125

EC 175

**Electronic cubers
with storage
and PWD system**

INDICE

Table of contents	page	2
Specifications EC 45		3
Specifications EC 55		5
Specifications EC 85		7
Specifications EC 105		9
Specifications EC 125		11
Specifications EC 175		13

GENERAL INFORMATION AND INSTALLATION

Introduction	15
Unpacking and Inspection	15
Location and levelling	15
Electrical connections	15
Water supply and drain connections	16
Final check list	17
Installation practice	17

OPERATING INSTRUCTIONS

Start up	18
Operational checks	19

OPERATING PRINCIPLES (How it works)

Freezing cycle	24
Harvest cycle	27
Control sequence	30
Component description	31

ADJUSTMENT, REMOVAL AND REPLACEMENT PROCEDURES

Adjustment of the cube size	35
Wiring diagram EC 45-55-85-105	36
Wiring diagram EC 125-175	37
Service diagnosis	38

MAINTENANCE AND CLEANING INSTRUCTIONS

General	41
Icemaker	41
Cleaning instructions of water system	42

SPECIFICATIONS

ELECTRONIC CUBER MODEL EC 45

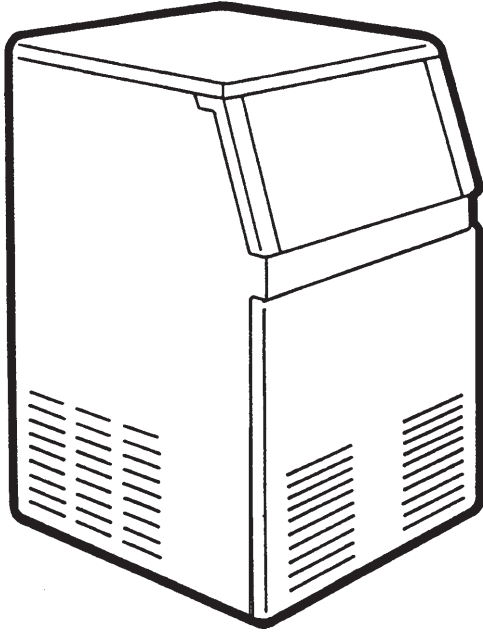

Important operating requirements:

	MIN.	MAX.
Air temperature	10°C	40°C
Water temperature	5°C	40°C
Water pressure	1 bar	5 bar
Electr. voltage variations from voltage rating specified on nameplate	-10%	+10%

ice making capacity

AIR COOLED MODELS

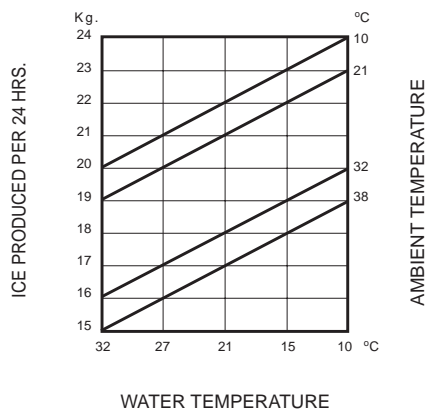

WATER COOLED MODELS

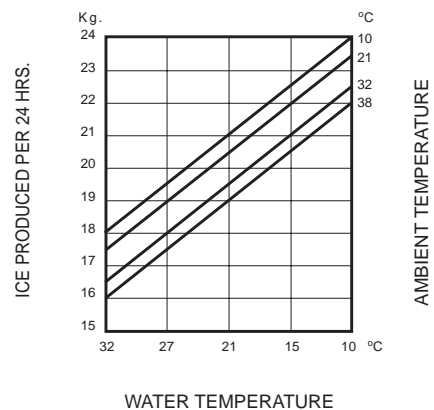

NOTE. With the unit in "built-in" conditions, the ice production is gradually reduced in respect to the levels shown in the graf, up to a maximum of 10% at room temperatures higher than 32° C. The daily ice-making capacity is directly related to the condenser air inlet temperature, water temperature and age of the machine. To keep your SCOTSMAN CUBER at peak performance levels, periodic maintenance checks must be carried out as indicated on page 41 of this manual.

SPECIFICATIONS

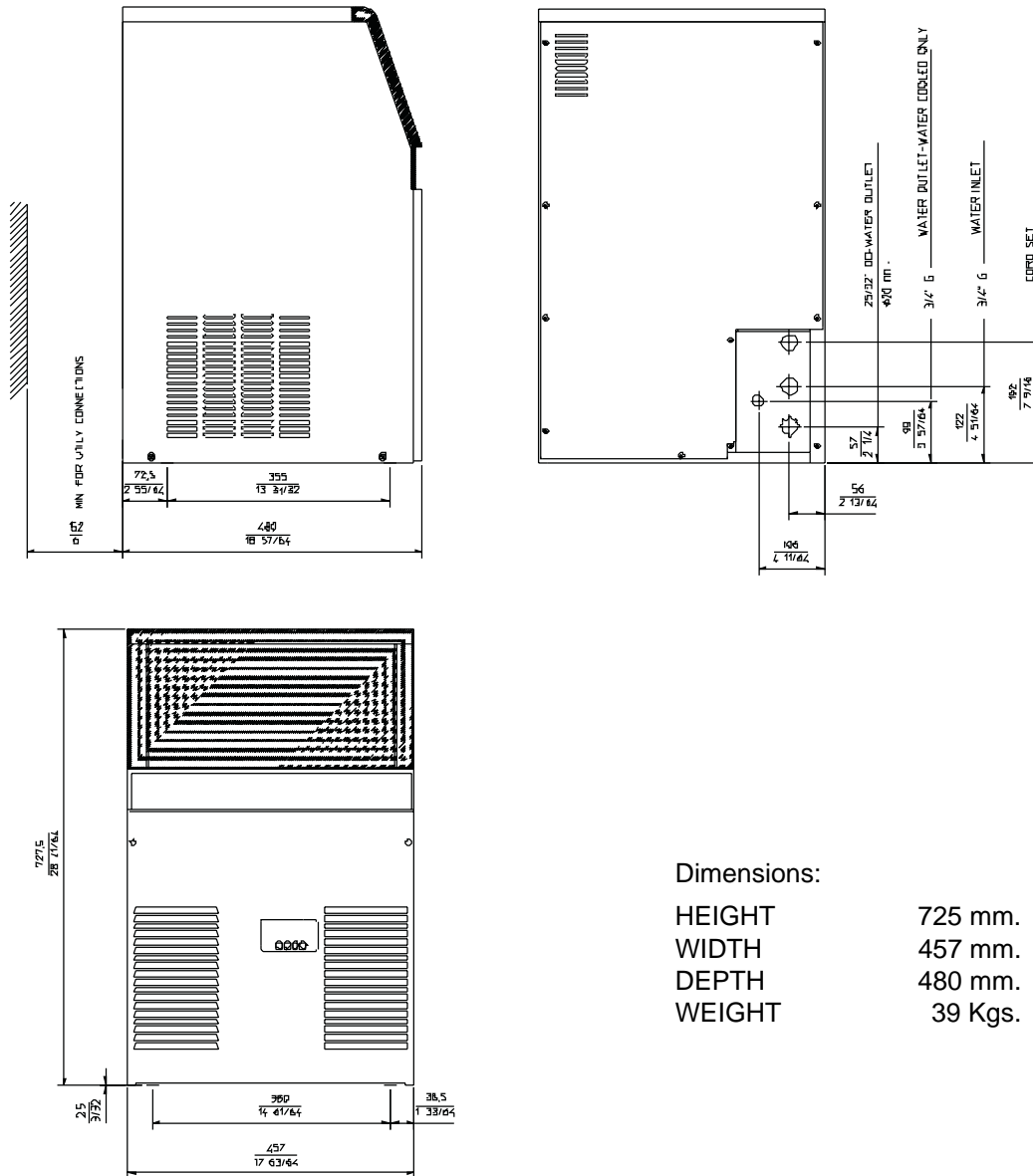

Dimensions:

HEIGHT 725 mm.
 WIDTH 457 mm.
 DEPTH 480 mm.
 WEIGHT 39 Kgs.

EC 45 - CUBER
 machine specifications

Model	Cond. unit	Finish	Comp. HP	Capacity the cold store	Water req. lt/24 HR
EC 45 AS 6	Air	Stainless steel	1/4	14 Kg.	100
EC 45 WS 6	Water				270*

Basic electr.	Amps	Start Amps	Watts	Electric power cons. Kwh per 24 Hr	Nr. of wires	Amps fuse
230/50/1	2.2	11	340	6.5	3 x 1.5 mm ²	10

Cubes per harvest: 18 medium
 * A 15°C water temperature

SPECIFICATIONS

ELECTRONIC CUBER MODEL EC 55

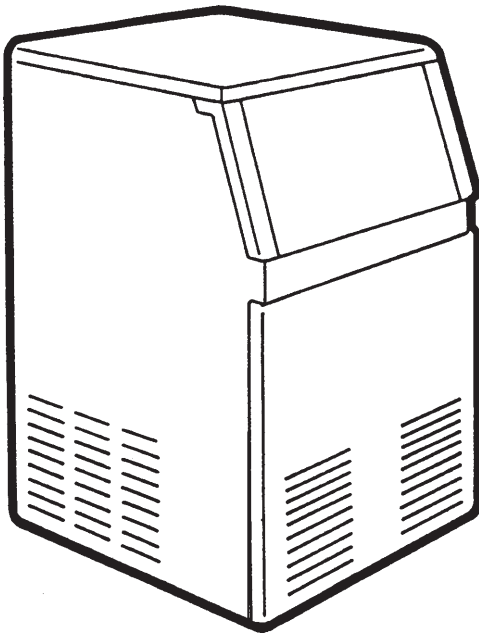

Important operating requirements:

	MIN.	MAX.
Air temperature	10°C	40°C
Water temperature	5°C	40°C
Water pressure	1 bar	5 bar
Electr. voltage variations from voltage rating specified on nameplate	-10%	+10%

ice making capacity

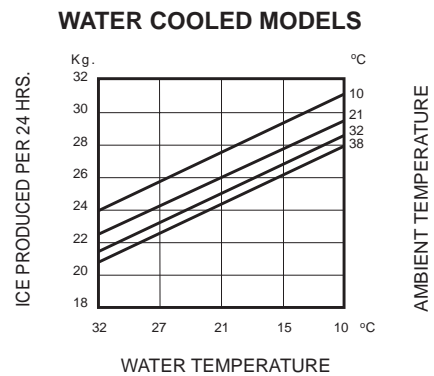
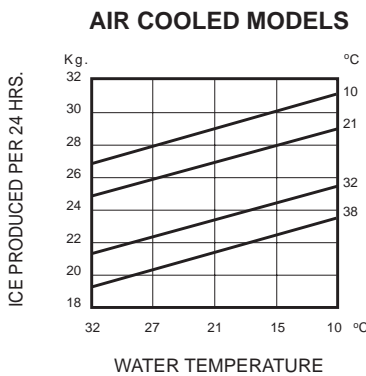

NOTE. With the unit in "built-in" conditions, the ice production is gradually reduced in respect to the levels shown in the graf, up to a maximum of 10% at room temperatures higher than 32°C. The daily ice-making capacity is directly related to the condenser air inlet temperature, water temperature and age of the machine. To keep your SCOTSMAN CUBER at peak performance levels, periodic maintenance checks must be carried out as indicated on page 41 of this manual.

SPECIFICATIONS

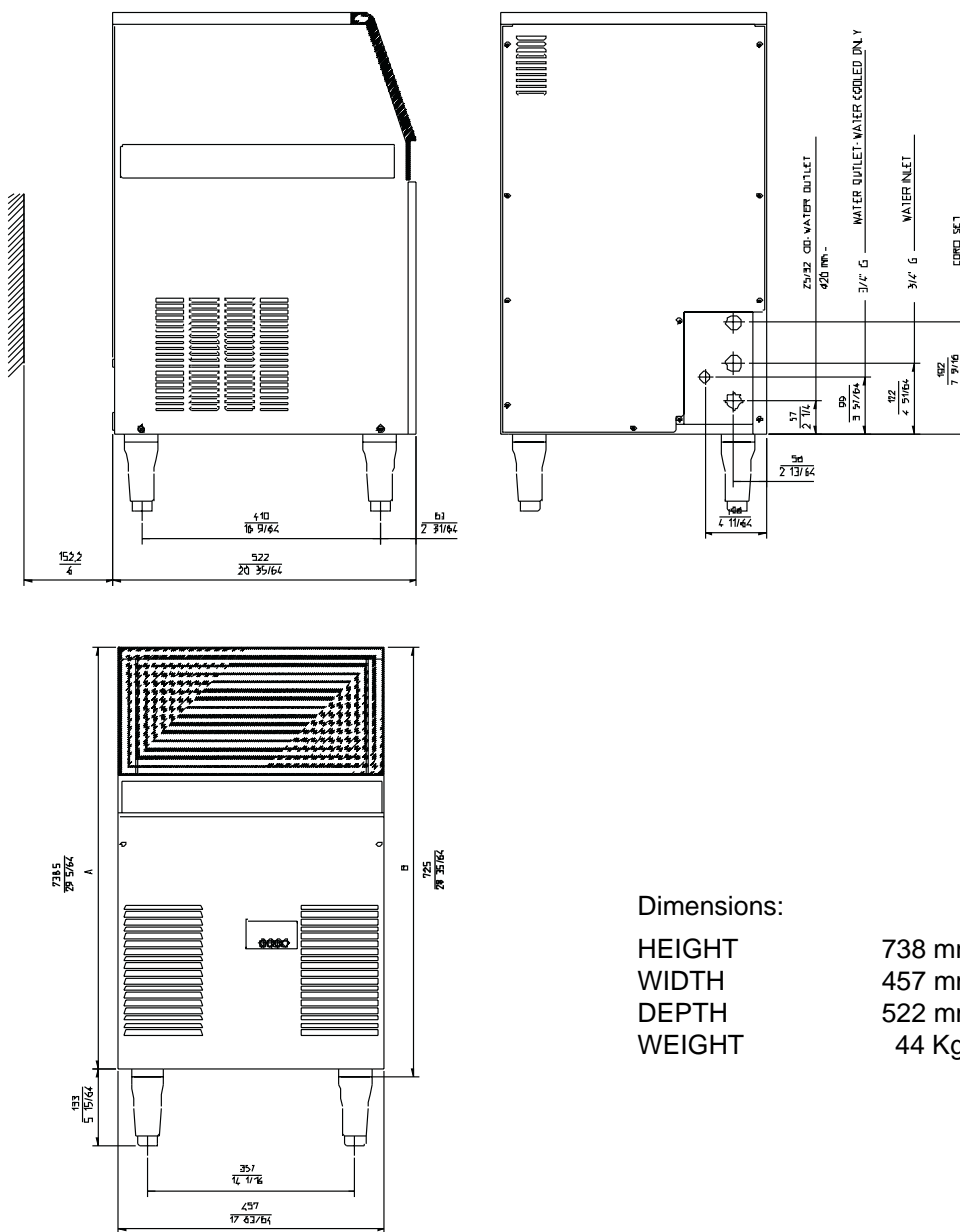

Dimensions:

HEIGHT 738 mm.
 WIDTH 457 mm.
 DEPTH 522 mm.
 WEIGHT 44 Kgs.

EC 55 - CUBER machine specifications

Model	Cond. unit	Finish	Comp. HP	Capacity the cold store	Water req. lt/24 HR	
EC 55 AS 6 EC 55 WS 6	Air Water	Stainless steel	1/4	14 Kg.	110 290*	
Basic electr.	Amps	Start Amps	Watts	Electric power cons. Kwh per 24 Hr	Nr. of wires	Amps fuse
230/50/1	2.2	11	390	7	3 x 1.5 mm ²	10
Cubes per harvest: 24 medium * A 15°C water temperature						

SPECIFICATIONS

ELECTRONIC CUBER MODEL EC 85

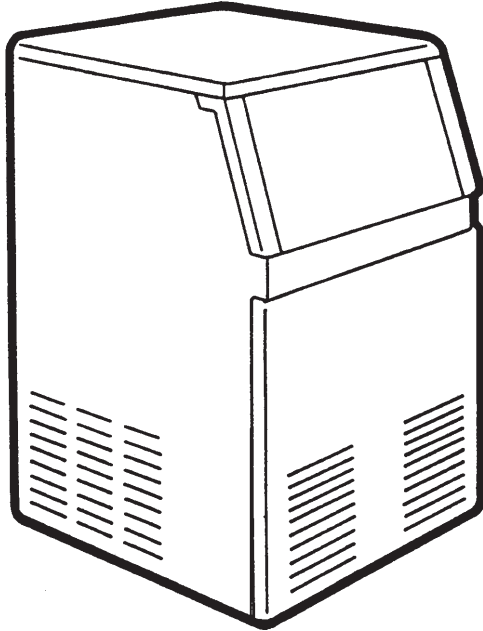

Important operating requirements:

	MIN	MAX
Air temperature	10°C (50°F)	40°C (100°F)
Water temperature	5°C (40°F)	40°C (100°F)
Water pressure	1 bar (14 psi)	5 bar (70 psi)
Electr. voltage variations from voltage rating specified on nameplate	-10%	+10%

ice making capacity

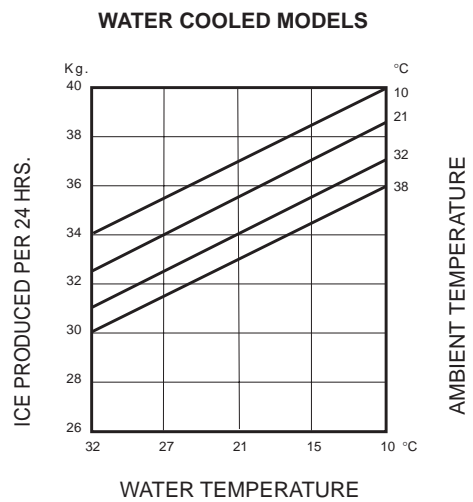
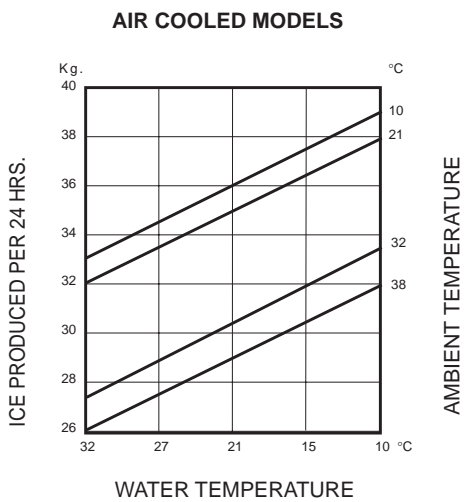

NOTE. With the unit in "built-in" conditions, the ice production is gradually reduced in respect to the levels shown in the graf, up to a maximum of 10% at room temperatures higher than 32°C. The daily ice-making capacity is directly related to the condenser air inlet temperature, water temperature and age of the machine. To keep your SCOTSMAN CUBER at peak performance levels, periodic maintenance checks must be carried out as indicated on page 41 of this manual.

SPECIFICATIONS

ELECTRONIC CUBER MODEL EC 105

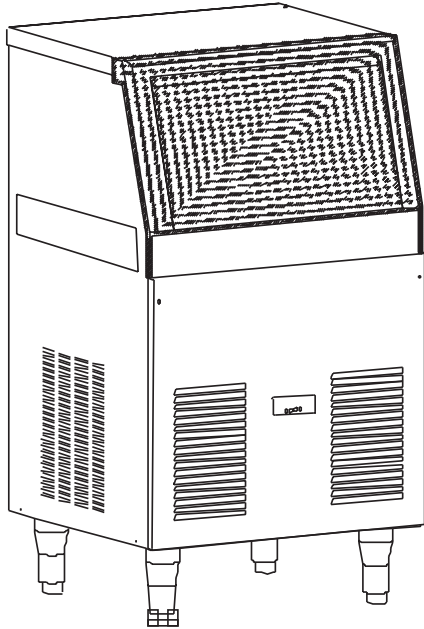

Important operating requirements:

	MIN	MAX
Air temperature	10°C (50°F)	40°C (100°F)
Water temperature	5°C (40°F)	40°C (100°F)
Water pressure	1 bar (14 psi)	5 bar (70 psi)
Electr. voltage variations from voltage rating specified on nameplate	-10%	+10%

ice making capacity

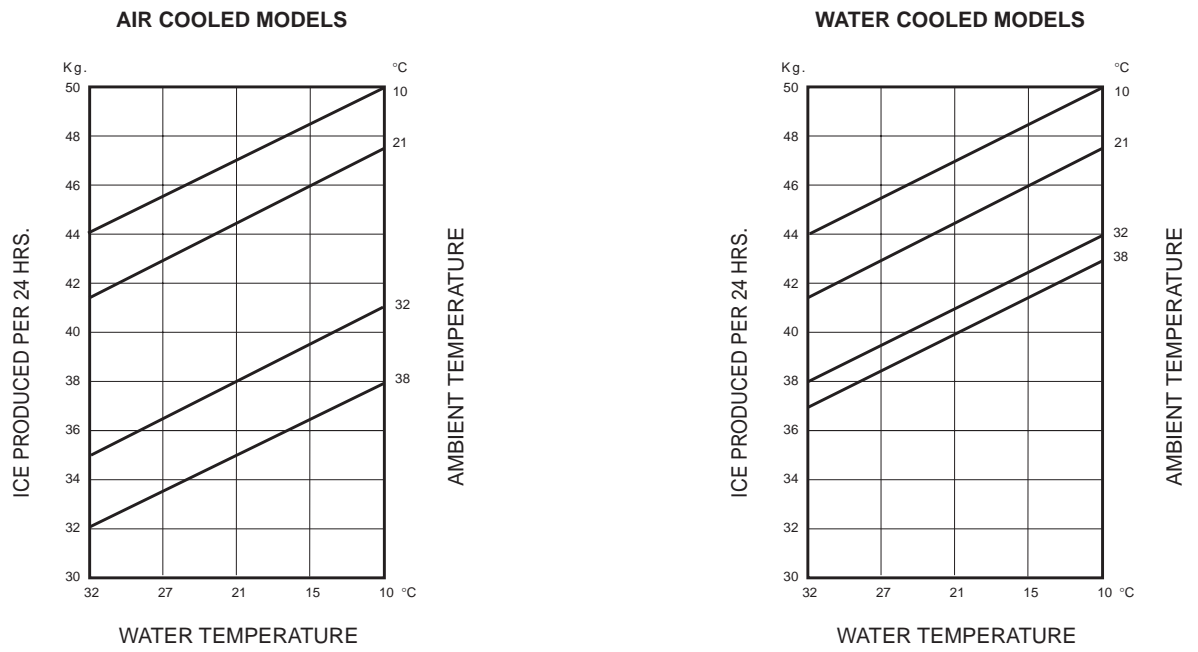

NOTE. With the unit in "built-in" conditions, the ice production is gradually reduced in respect to the levels shown in the graf, up to a maximum of 10% at room temperatures higher than 32°C. The daily ice-making capacity is directly related to the condenser air inlet temperature, water temperature and age of the machine. To keep your SCOTSMAN CUBER at peak performance levels, periodic maintenance checks must be carried out as indicated on page 41 of this manual.

SPECIFICATIONS (CONT'D)

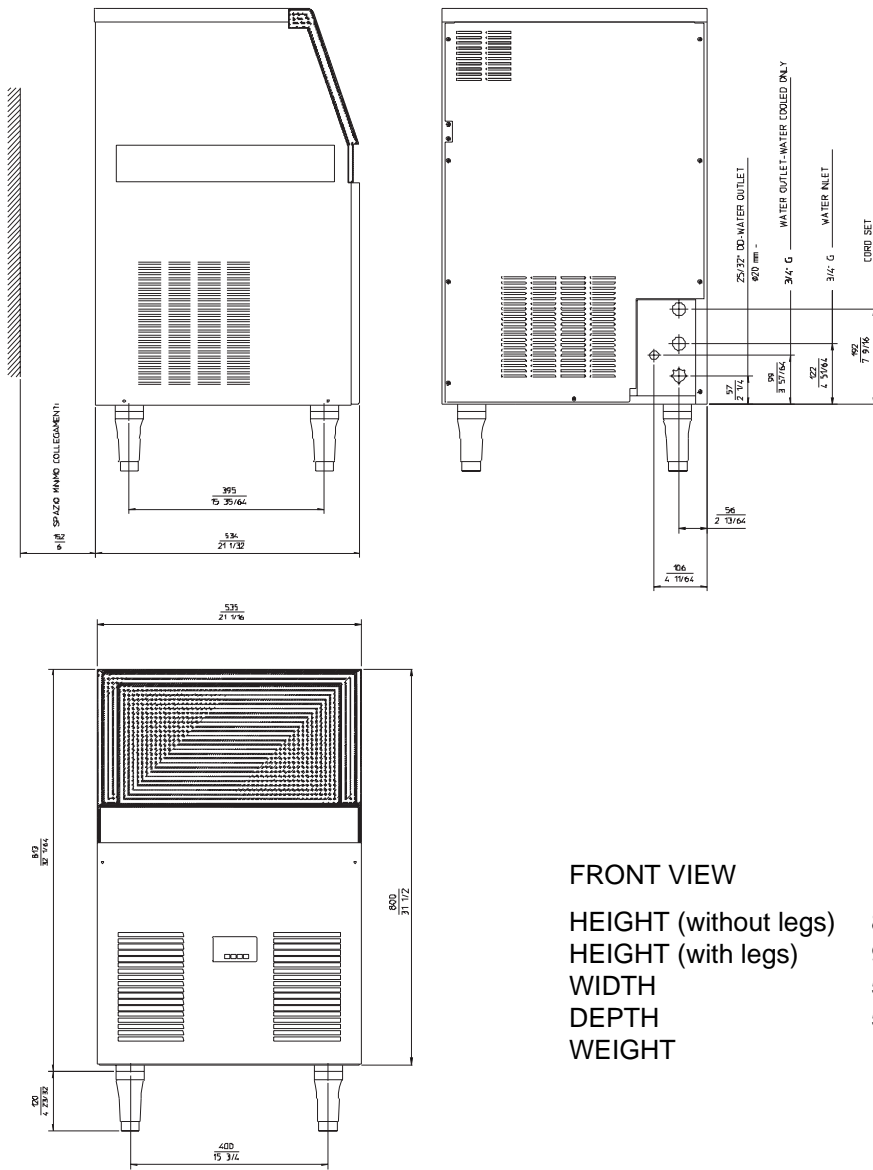

FRONT VIEW
 HEIGHT (without legs) 813 mm.
 HEIGHT (with legs) 950 mm.
 WIDTH 535 mm.
 DEPTH 534 mm.
 WEIGHT 44 Kgs.

**EC 105 - CUBER
 machine specifications**

Model	Cond.	Finish	Comp. HP	Ice bin cap. Kgs.	Water requirem LTx24 HR
EC 105 AS	Air	S/Steel	3/8	18	180
EC 105 WS	Water	S/Steel			530*

Basic electr.	Amps.	Start Amps	Watts	Electr. power cons. Kwh per 24 Hrs	No of Wires	Amp. Fuse
230/50/1	3.5	18	550	10	3 x 1.5 mm ²	10

Cubes per harvest: 32 medium
 * At 15°C water temperature

SPECIFICATIONS

ELECTRONIC CUBER MODEL EC 125

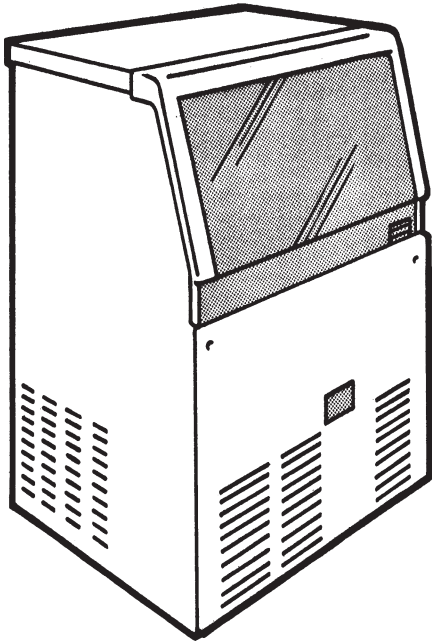

Important operating requirements:

	MIN	MAX
Air temperature	10°C (50°F)	40°C (100°F)
Water temperature	5°C (40°F)	40°C (100°F)
Water pressure	1 bar (14 psi)	5 bar (70 psi)
Electr. voltage variations from voltage rating specified on nameplate	-10%	+10%

ice making capacity

AIR COOLED MODELS

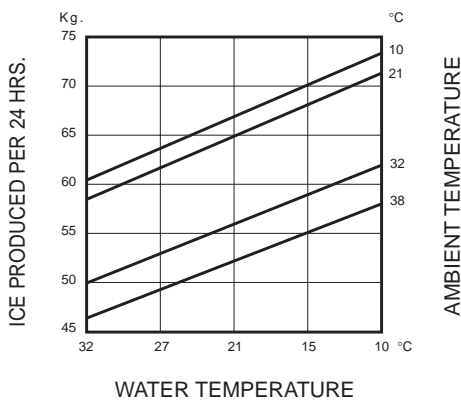

WATER COOLED MODELS

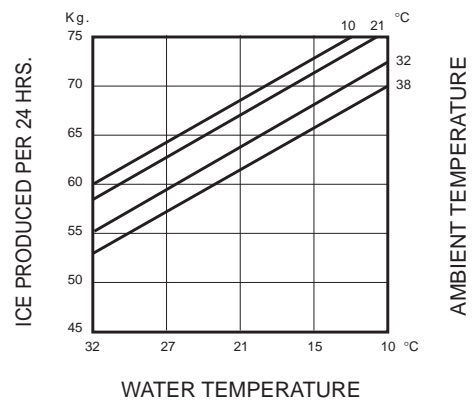

NOTE. With the unit in "built-in" conditions, the ice production is gradually reduced in respect to the levels shown in the graf, up to a maximum of 10% at room temperatures higher than 32° C. The daily ice-making capacity is directly related to the condenser air inlet temperature, water temperature and age of the machine. To keep your SCOTSMAN CUBER at peak performance levels, periodic maintenance checks must be carried out as indicated on page 41 of this manual.

SPECIFICATIONS (CONT'D)

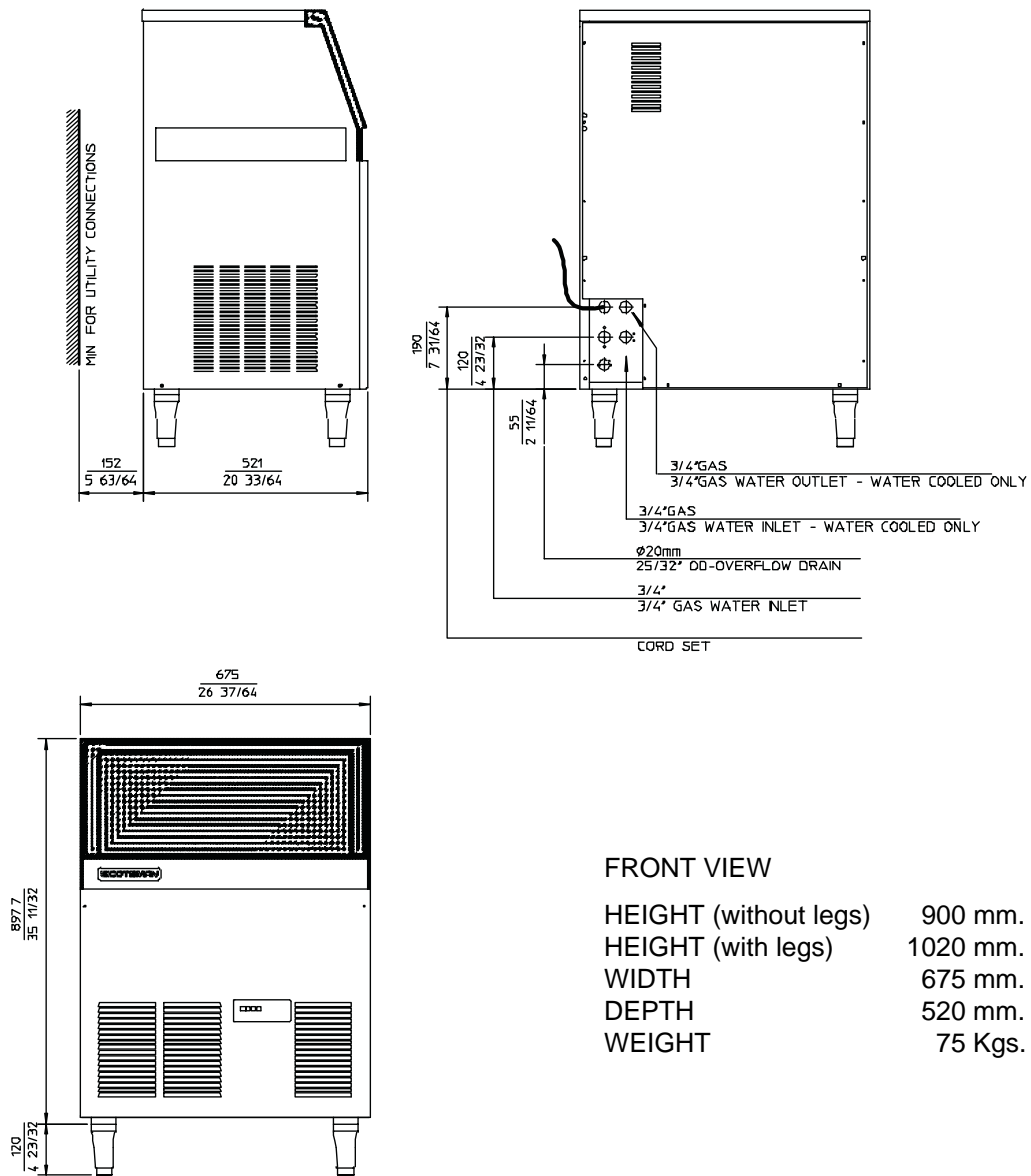

FRONT VIEW

HEIGHT (without legs) 900 mm.
 HEIGHT (with legs) 1020 mm.
 WIDTH 675 mm.
 DEPTH 520 mm.
 WEIGHT 75 Kgs.

**EC 125 - CUBER
 machine specifications**

Model	Cond.	Finish	Comp. HP	Ice bin cap. Kgs.	Water requirem LTx24 HR
EC 125 AS	Air	S/Steel	1/2	28	160
EC 125 WS	Water	S/Steel			680*

Basic electr.	Amps.	Start Amps	Watts	Electr. power cons. Kwh per 24 Hrs	No of Wires	Amp. Fuse
230/50/1	3.8	20	670	13	3 x 1.5 mm ²	10

Cubes per harvest: 36 large / 48 medium / 84 small
 * At 15°C water temperature

SPECIFICATIONS

ELECTRONIC CUBER MODEL EC 175

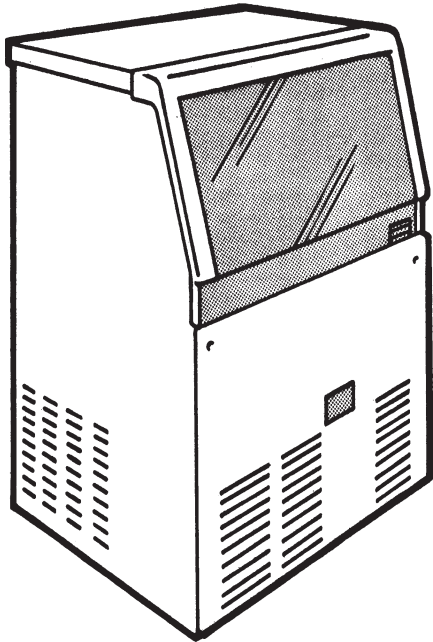

Important operating requirements:

	MIN	MAX
Air temperature	10°C (50°F)	40°C (100°F)
Water temperature	5°C (40°F)	40°C (100°F)
Water pressure	1 bar (14 psi)	5 bar (70 psi)
Electr. voltage variations from voltage rating specified on nameplate	-10%	+10%

ice making capacity

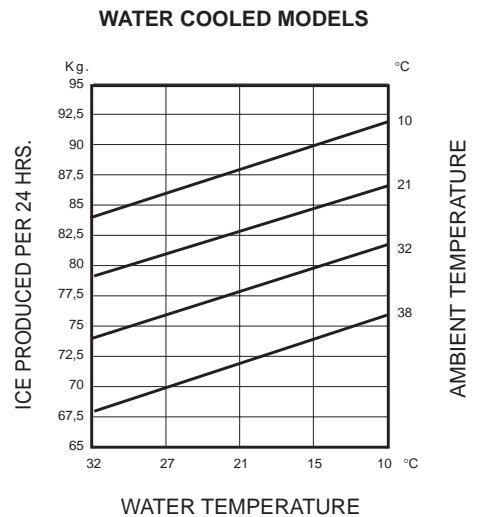
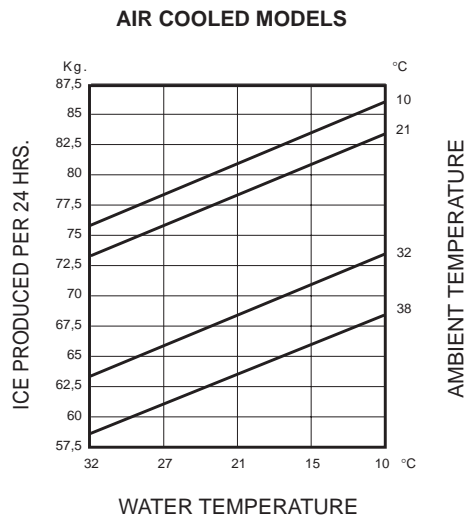

NOTE. With the unit in "built-in" conditions, the ice production is gradually reduced in respect to the levels shown in the graf, up to a maximum of 10% at room temperatures higher than 32° C. The daily ice-making capacity is directly related to the condenser air inlet temperature, water temperature and age of the machine. To keep your SCOTSMAN CUBER at peak performance levels, periodic maintenance checks must be carried out as indicated on page 41 of this manual.

SPECIFICATIONS (CONT'D)

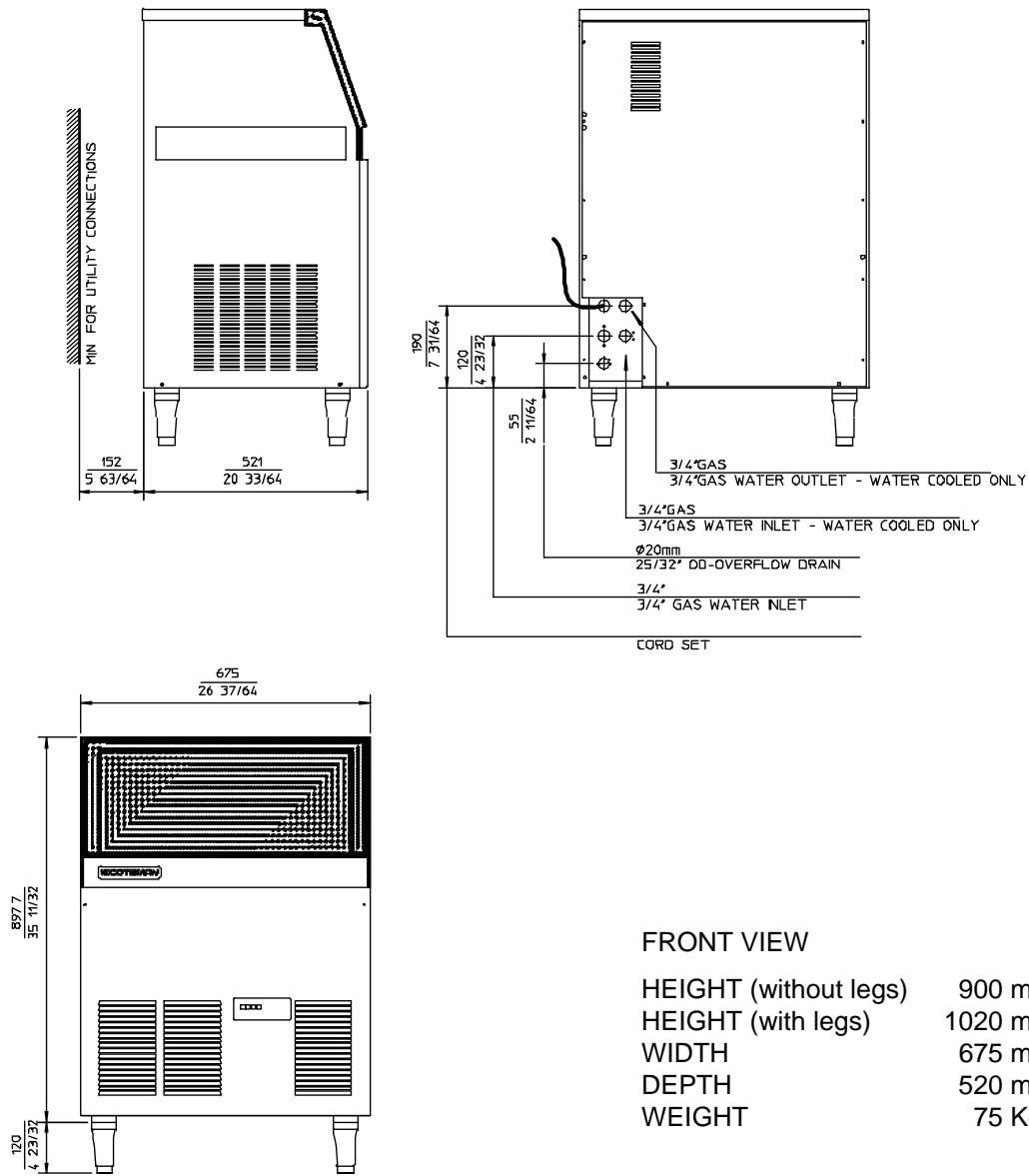

FRONT VIEW
 HEIGHT (without legs) 900 mm.
 HEIGHT (with legs) 1020 mm.
 WIDTH 675 mm.
 DEPTH 520 mm.
 WEIGHT 75 Kgs.

**EC 175 - CUBER
 machine specifications**

Model	Cond.	Finish	Comp. HP	Ice bin cap. Kgs.	Water requirem LTx24 HR
EC 175 AS	Air	S/Steel	3/4	28	160
EC 175 WS	Water	S/Steel			1000*

Basic electr.	Amps.	Start Amps	Watts	Electr. power cons. Kwh per 24 Hrs	No of Wires	Amp. Fuse
230/50/1	5.3	29	850	18	3 x 1.5 mm ²	16

Cubes per harvest: 36 large / 48 medium
 * At 15°C water temperature

GENERAL INFORMATION AND INSTALLATION

A. INTRODUCTION

This manual provides the specifications and the step-by-step procedures for the installation, start-up and operation, maintenance and cleaning for the SCOTSMAN EC series icemakers.

The Electronic Cubers are quality designed, engineered and manufactured.

Their ice making systems are thoroughly tested providing the utmost in flexibility to fit the needs of a particular user.

These icemakers have been engineered to our own rigid safety and performance standards.

NOTE. *To retain the safety and performance built into this icemaker, it is important that installation and maintenance be conducted in the manner outlined in this manual.*

B. UNPACKING AND INSPECTION

1. Call your authorized SCOTSMAN Distributor or Dealer for proper installation.
2. Visually inspect the exterior of the packing and skid. Any severe damage noted should be reported to the delivering carrier and a concealed damage claim form filled in subject to inspection of the contents with the carrier's representative present.
3.
 - a) Cut and remove the plastic strip securing the carton box to the skid.
 - b) Cut open the top of the carton and remove the polystyrene protection sheet.
 - c) Pull out the polystyrene posts from the corners and then remove the carton.
4. Remove the front panel of the unit and inspect for any concealed damage. Notify carrier of your claim for the concealed damage as stated in step 2 above.
5. Check that refrigerant lines do not rub against or touch other lines or surfaces, and that the fan blade moves freely.
6. Check that the compressor fits snugly onto all its mounting pads.
7. Remove all internal support packing and masking tape.



8. Use clean damp cloth to wipe the surfaces inside the storage bin and the outside of the cabinet.

9. See data plate on the rear side of the unit and check that local main voltage corresponds with the voltage specified on it.

CAUTION. **Incorrect voltage supplied to the icemaker will void your parts replacement program.**

10. Remove the manufacturer's registration card from the inside of the User Manual and fill-in all parts including: Model and Serial Number taken from the data plate.

Forward the completed self-addressed registration card to Frimont factory.

11. If necessary, fit the four legs (not on EC 45) into their seats on the machine base and adjust them to the desired level.

C. LOCATION AND LEVELLING

WARNING. **This Ice Cuber is designed for indoor installation only. Extended periods of operation at temperatures exceeding the following limitations will constitute misuse under the terms of the SCOTSMAN Manufacturer's Limited Warranty resulting in LOSS of warranty coverage.**

1. Position the unit in the selected permanent location.
Criteria for selection of location include:
 - a) Minimum room temperature 10°C (50°F) and maximum room temperature 40°C (100°F).
 - b) Water inlet temperatures: minimum 5°C (40°F) and maximum 35°C (90°F).
 - c) Well ventilated location for air cooled models.
 - d) Service access: adequate space must be left for all service connections through the rear of the ice maker. A minimum clearance of 15 cm (6") must be left at the sides of the unit for routing cooling air drawn into and exhausted out of the compartment to maintain proper condensing operation of air cooled models.
2. Level the unit in both the left to right and front to rear directions.

D. ELECTRICAL CONNECTIONS

See data plate for current requirements to determine wire size to be used for electrical connections. All SCOTSMAN icemakers require a solid earth wire.

All SCOTSMAN ice machines are supplied from the factory completely pre-wired and require only electrical power connections to the wire cord provided at rear of the unit.

Make sure that the ice machine is connected to its own circuit and individually fused (see data plate for fuse size).

The maximum allowable voltage variation should not exceed -10% and + 10% of the data plate rating. Low voltage can cause faulty functioning and may be responsible for serious damage to the overload switch and motor windings.

NOTE. All external wiring should conform to national, state and local standards and regulations.

Check voltage on the line and the ice maker's data plate before connecting the unit.

E. WATER SUPPLY AND DRAIN CONNECTIONS

GENERAL

When choosing the water supply for the ice cuber consideration should be given to:

- Length of run
- Water clarity and purity
- Adequate water supply pressure

Since water is the most important single ingredient in producing ice you cannot emphasize too much the three items listed above.

Low water pressure, below 1 bar may cause malfunction of the ice maker unit.

Water containing excessive minerals will tend to produce cloudy coloured ice cubes, plus scale build-up on parts of the water system.

WATER SUPPLY

Air Cooled Versions

Connect the 3/4" male fitting of the solenoid water inlet valve, using the flexible tube supplied, to the cold water supply line with regular plumbing fitting and a shut-off valve installed in an accessible position between the water supply line and the unit.

If water contains a high level of impurities, it is advisable to consider the use an appropriate water filter or conditioner.

Water Cooled Versions - EC 45-55-85-105

On Water Cooled version the water inlet solenoid valve has two separate outhets one for the condenser and the second for the production of ice.

Water Cooled Versions - EC 125-175

The water cooled versions require two separate inlet water supplies, one for water sprayed for making the ice cubes and the other for the water cooled condenser.

Connect the 3/4" male fitting of the water inlet of condenser using the flexible tube supplied to the cold water supply line with regular plumbing fitting and a shut-off valve installed in an accessible position between the water supply line and the unit.

WATER DRAIN

The recommended drain tube is a plastic or flexible tube with 18 mm (3/4") I.D. which runs to an open trapped and vented drain.

WATER DRAIN - WATER COOLED MODELS

Connect the 3/4" male fitting of the condenser water drain, utilizing a second flexible hose, to the open trapped and vented drain.

NOTE. The water supply and the water drain must be installed to conform with the local code. In some case a licensed plumber and/ or a plumbing permit is required.

The EC series Ice Cubers can pump out water up to 1.5 m rise

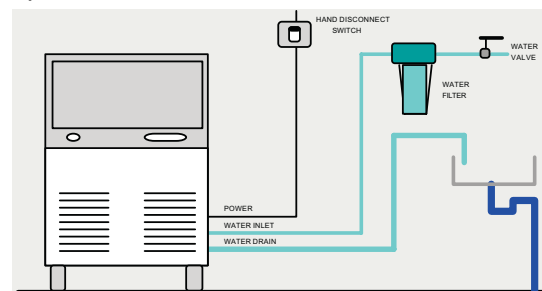

or to 30 m on horizontal length.

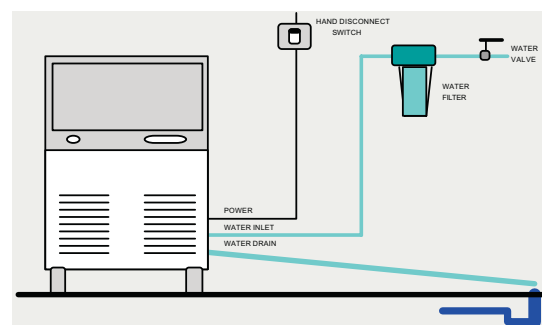

F. FINAL CHECK LIST

1. Is the unit in a room where ambient temperatures are within a minimum of 10°C (50°F) even in winter months?
2. Is there at least a 15 cm (6") clearance around the unit for proper air circulation?
3. Is the unit level? (IMPORTANT)
4. Have all the electrical and plumbing connections been made, and is the water supply shut-off valve open?
5. Has the voltage been tested and checked against the data plate rating?
6. Has the water supply pressure been checked to ensure a water pressure of at least 1 bar (14 psi).

7. Check all refrigerant lines and conduit lines to guard against vibrations and possible failure.
8. Have the bolts holding the compressor down been checked to ensure that the compressor is snugly fitted onto the mounting pads?
9. Have the bin liner and cabinet been wiped clean?
10. Has the owner/user been given the User Manual and been instructed on the importance of periodic maintenance checks?
11. Has the Manufacturer's registration card been filled in properly? Check for correct model and serial number against the serial plate and mail the registration card to the factory.
12. Has the owner been given the name and the phone number of the authorized SCOTSMAN Service Agency serving him?

G. INSTALLATION PRACTICE

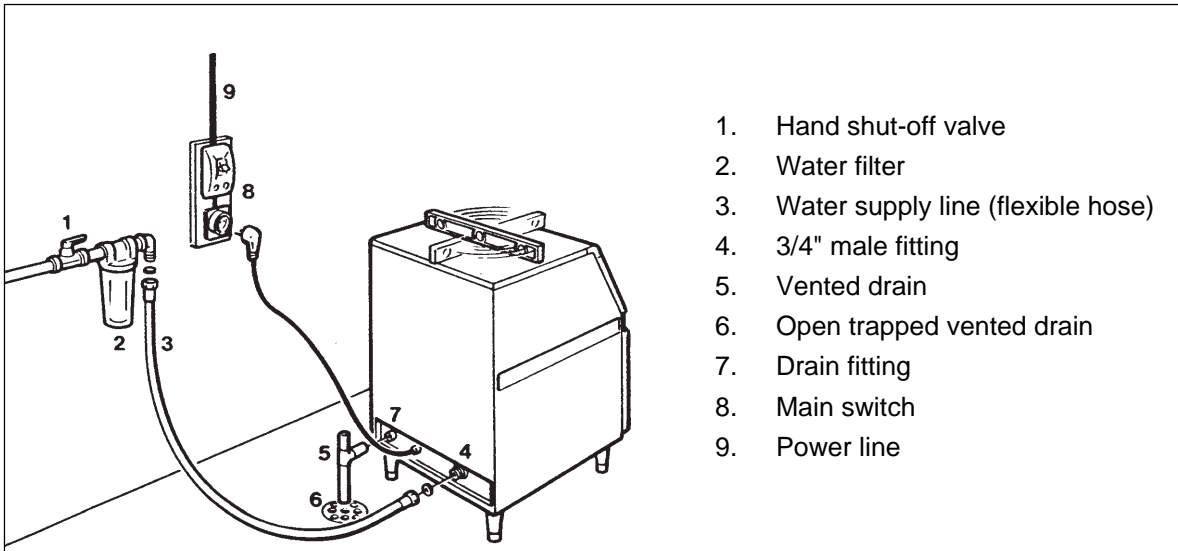

WARNING. This icemaker is not designed for outdoor installation and will not function in ambient temperatures below 10°C (50°F) or above 40°C (100°F). This icemaker will malfunction with water temperatures below 5°C (40°F) or above 35°C (90°F).

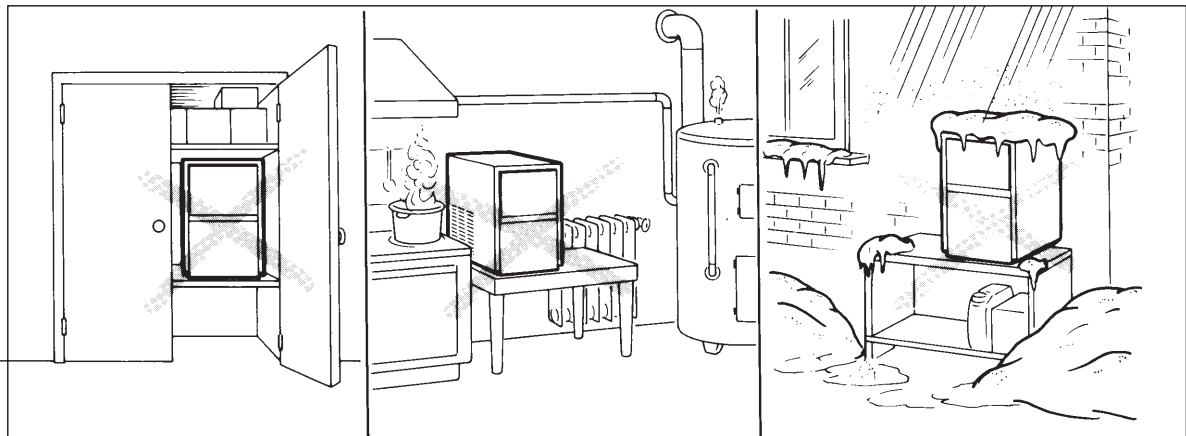

OPERATING INSTRUCTIONS

START UP

After having correctly installed the ice maker and completed the plumbing and electrical connections, perform the following "Start-up" procedure.

A. Give power to the unit to start it up by switching "ON" the power line main disconnect switch.

NOTE. Every time the unit returns under power, after having been switched off, the water inlet valve, the hot gas valve and the water drain valve get energized for a period of 5 minutes, thus to admit new water to the machine sump reservoir to fill it up and, eventually, to wash-off any dirt that can have deposited in it during the unit off period (Fig.1).

During the water filling phase the components energized are:

- THE WATER INLET SOLENOID VALVE**
- THE HOT GAS SOLENOID VALVE**
- THE WATER DRAIN SOLENOID VALVE**

NOTE. If in the 5 minutes length of the water filling phase the machine sump reservoir does not get filled with water up to the rim of the overflow pipe, it is advisable to check:

1. The water pressure of the water supply line that must be at least **1 bar (14 psig)** Minimum (Max 5 bar-70 psig).
2. The filtering device installed in the water line that may reduce the water pressure below the Minimum value of 1 bar (14 psig).
3. Any clogging situation in the water circuit like the inlet water strainer and/or the flow control.

B. During the water filling operation, check to see that the incoming water dribbles, through the evaporator platen dribbler holes, down into the sump reservoir to fill it up and also that the incoming surplus of water flows out through the overflow pipe into the drain line.

C. All water coming from the overflow is collected inside the Sealed Water Reservoir. As soon as the water reaches its maximum level, the Water Drain Pump is energized for 8 seconds pumping out most of the water contained into the Sealed Water Reservoir.

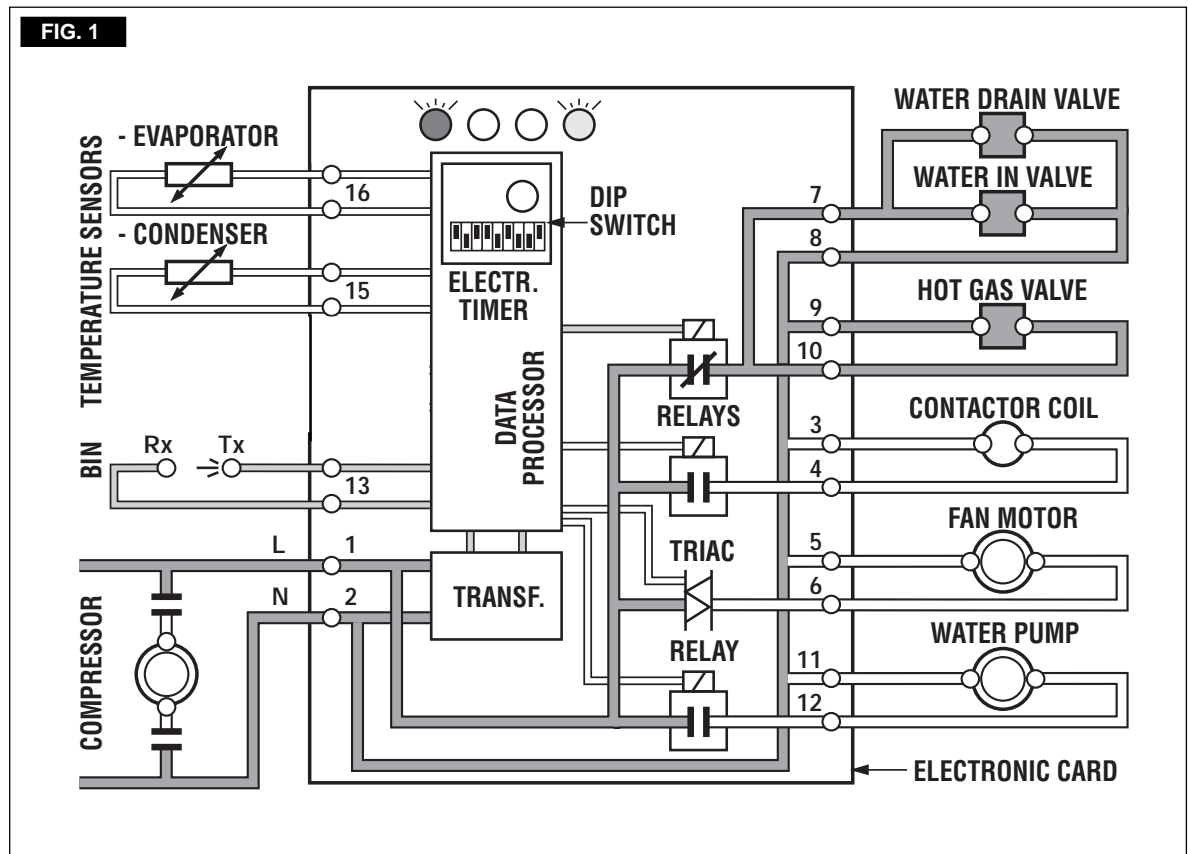

D. At completion of the water filling phase (5 minutes) the unit passes automatically into the freezing cycle with the start up of:

COMPRESSOR

CONTACTOR COIL (EC 125-175 only)

WATER PUMP

FAN MOTOR (in air cooled version) controlled by the condensing temperature sensor located within the condenser fins (Fig.2).

OPERATIONAL CHECKS

E. Install, if required, the refrigerant service gauges on both the high side and low side Scraeder valves to check the compressor head and suction pressures.

NOTE. On air cooled models, the condenser temperature sensor, which is located within the condenser fins, keep the head (condensing) pressure between 8.5 and 9.5 bar (110÷130 psig).

In case of condenser clogging such to prevent the proper flow of the cooling air or, in case the fan motor is out of operation or shortage of water in the water cooled condenser, the condenser temperature rises and when it reaches 70°C (160°F) - for air cooled version - or 60°C (140°F) - for water cooled version - the condenser temperature sensor shuts-off the ice maker with the consequent light-up of the RED WARNING LED (Fig.3).



After having diagnosed the reason of the rise of temperature and removed its cause, it is necessary to unplug (wait few seconds) and plug in again the unit, thus to put the machine in condition to initiate a new freezing cycle.

The machine restarts with the usual 5 minutes water filling phase in order to provide enough water into the sump tank.

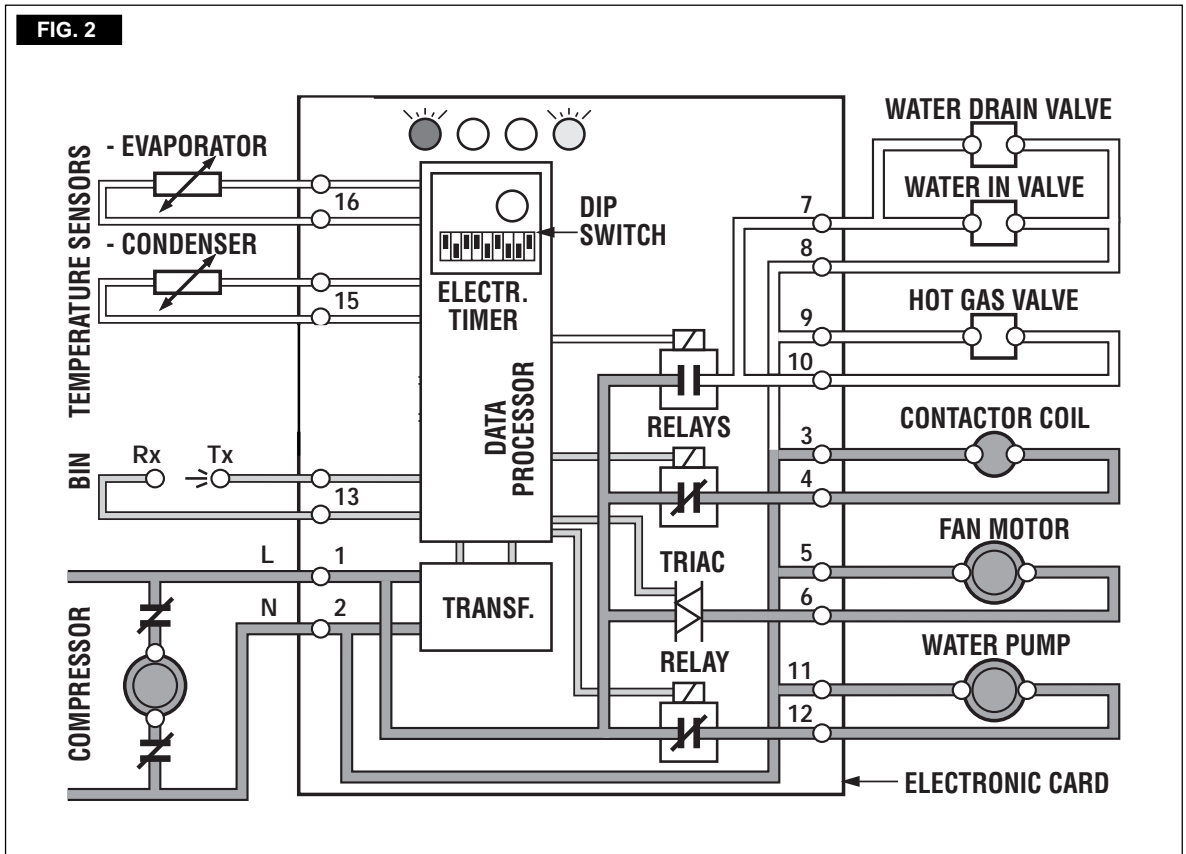

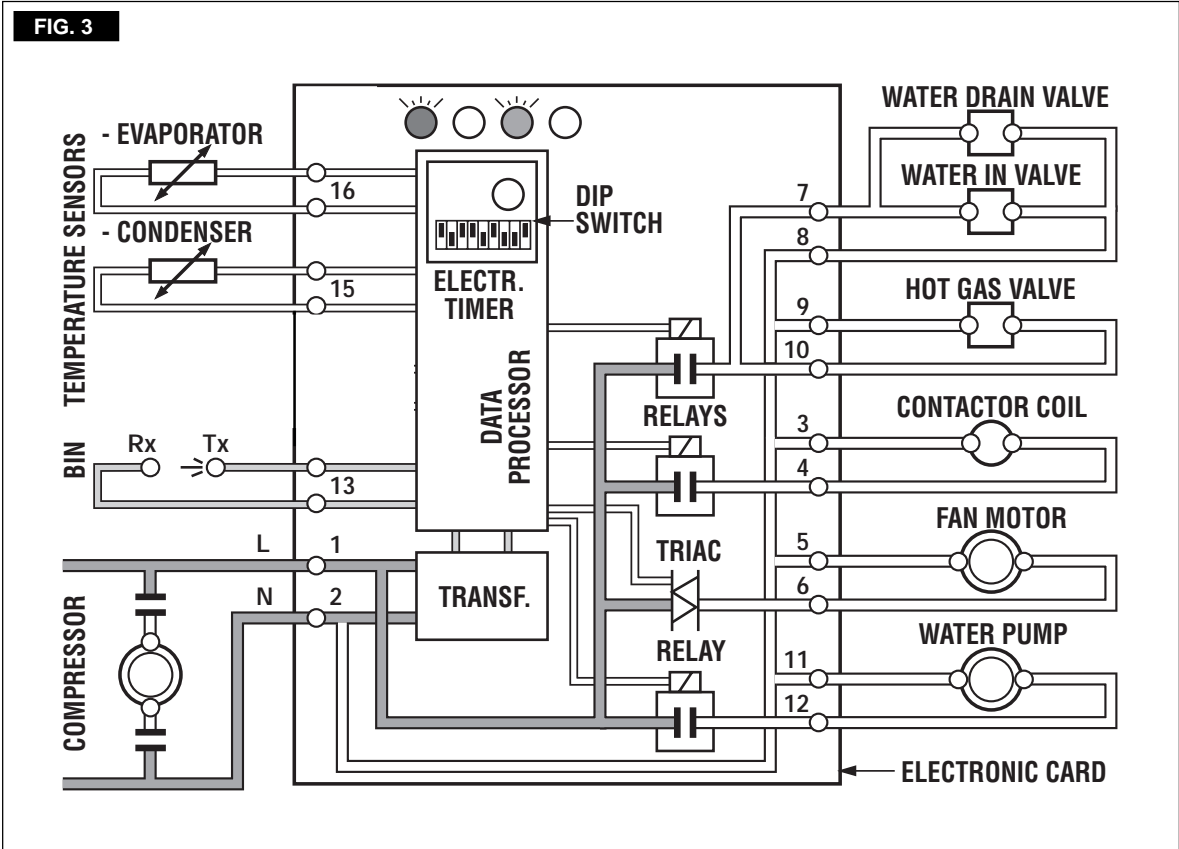

F. Check to see through the ice discharge opening that the spray system is correctly seated and that the water jets uniformly reach the

interior of the inverted mold cups; also make sure that the plastic curtain is hanging freely and there is not excessive water spilling through it.

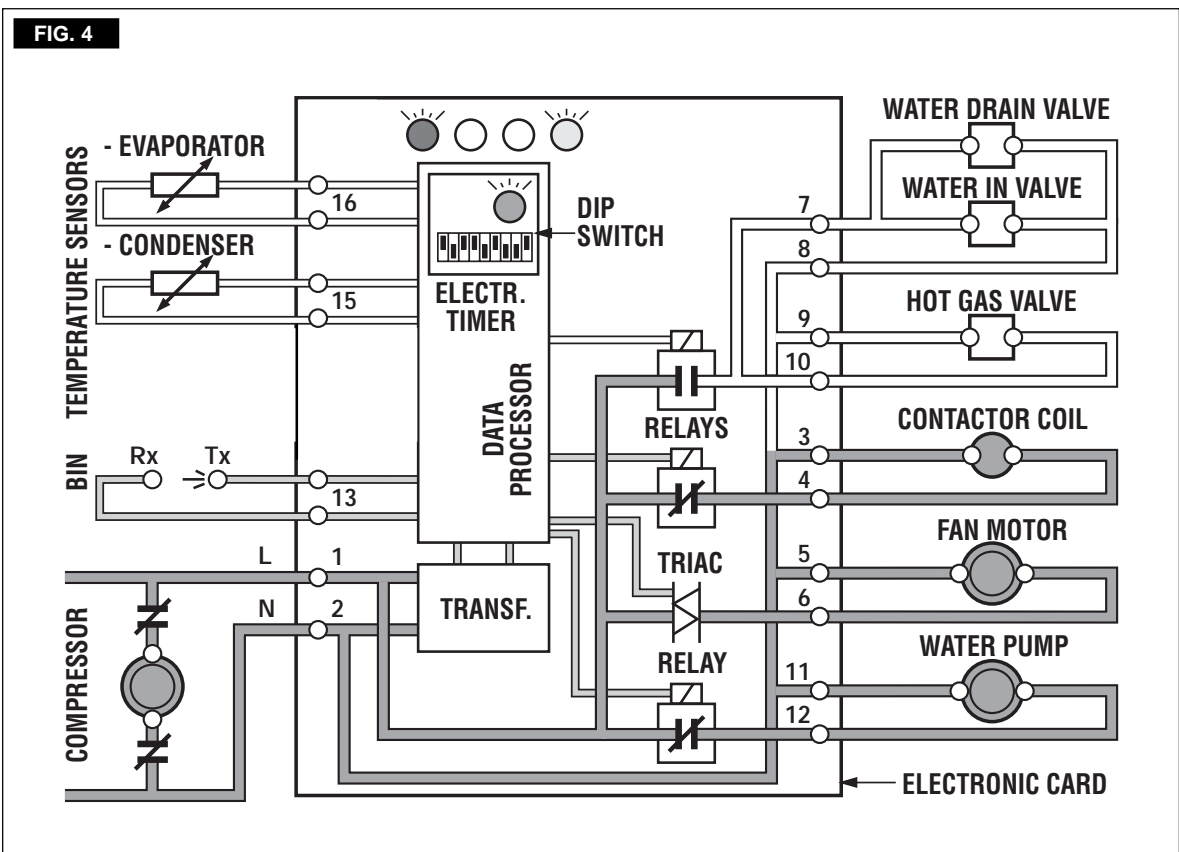

G. The ice making process takes place thereby, with the water sprayed into the molds that gets gradually refrigerated by the heat exchange with the refrigerant flowing into the evaporator serpentine. During the freezing process, when the evaporator temperature falls below an established value, the evaporator temperature sensor supplies a low voltage power signal to the electronic control device (P.C.BOARD) in order to activate an electronic timer. This one takes over the control of the freezing cycle up to the complete formation of the ice cubes (Fig.4).

NOTE. The length of the entire freezing cycle is governed by the evaporator temperature sensor which has its probe placed in contact with the evaporator serpentine (Non adjustable) in combination with the electronic timer (Adjustable) incorporated in the P.C.BOARD. The timer adjustment is factory set in consideration of the ice maker type, cooling version and ice cube size (Small, Medium, Large). It is possible, however, to modify the timed length of the freezing cycle, by changing the **DIP SWITCH** keys setting. In Table B of PRINCIPLE OF OPERATION are shown the various time extensions of the freezing cycle second phase, in relation with the different DIP SWITCH keys setting.

H. After about 17÷20 minutes from the beginning of the freezing cycle, in an hypothetic ambient temperature of 21°C, the defrost cycle takes place with the hot gas, the water inlet and the water drain valves simultaneously activated (Fig. 5).

The electrical components in operation on models are:

- COMPRESSOR**
 - CONTACTOR COIL** (EC 125-175 only)
 - WATER INLET VALVE**
 - HOT GAS VALVE**
 - WATER DRAIN VALVE**
- and the
- WATER PUMP**
- on the first 15 seconds.

NOTE. The length of the defrost cycle (not adjustable) is automatically determined by the micro-processor of the P.C. BOARD in relation of the time necessary for the unit to reduce the evaporator temperature from 0°C (32°F) small Red LED blinking to -15°C (5°F) small Red LED ON steady - TIME T2.

I. Check, during the defrost cycle, that the incoming water flows correctly into the sump reservoir in order to refill it and that the surplus overflows through the overflow drain tube.

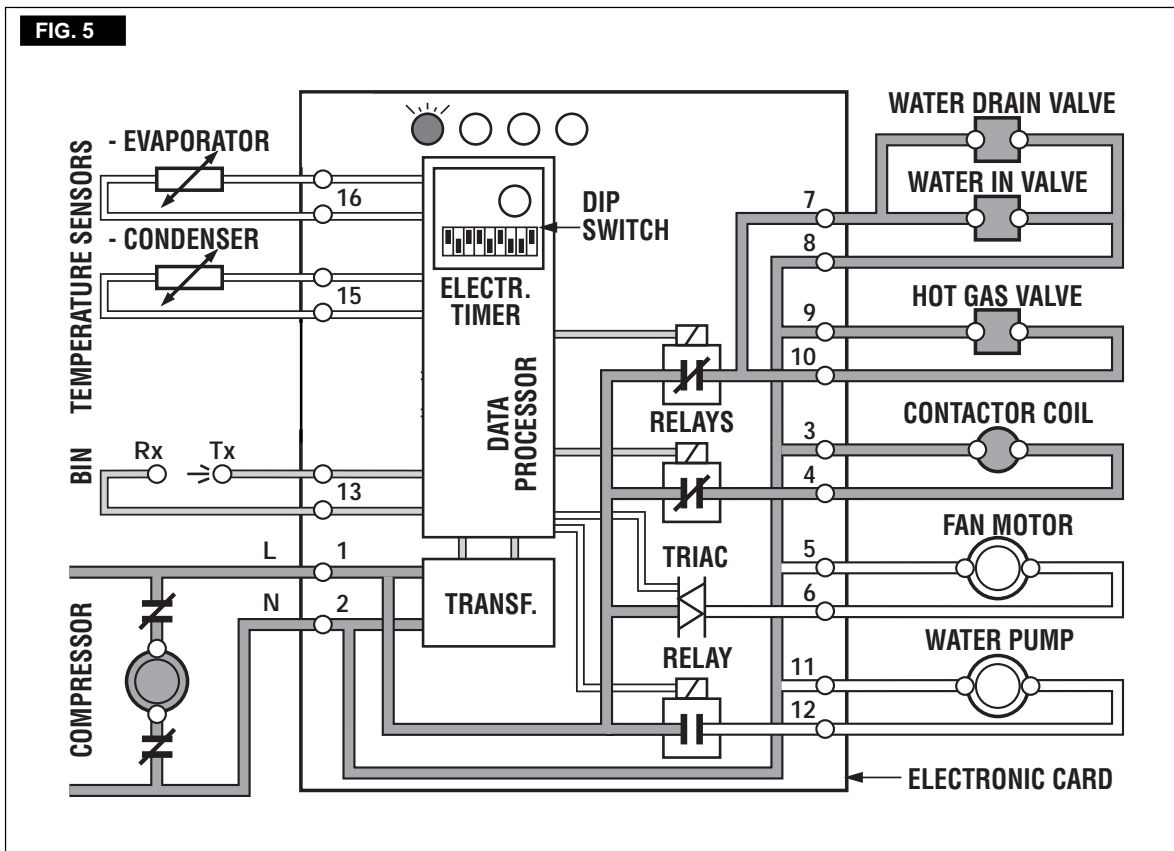

J. As soon as the water into the Sealed Water Reservoir reaches the maximum level, the two metal pins close the electrical contact through the water, transmitting a low voltage current to the Special Interface PC Board.

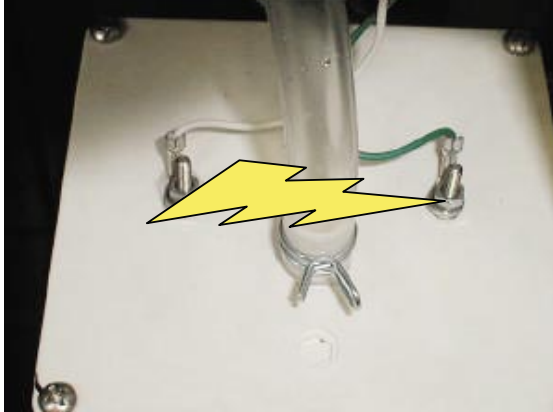

The Interface PC Board energises the Water Drain Pump for 8 seconds pumping out most of the water contained into the Sealed Water Reservoir.

K. Check the texture of ice cubes just released. They have to be in the right shape with a small depression of about 5-6 mm in their crown.

If not, wait for the completion of the second cycle before performing any adjustment. If the ice cubes are shallow and cloudy, it is possible that the ice maker runs short of water during the freezing cycle second phase or, the quality of the supplied water requires the use of an appropriate water filter or conditioner.

L. To be sure of the correct operation of ice level control device, place one hand between its sensing "eyes" to interrupt the light beam. The Bin Full **YELLOW LED** starts to blink, and after 60 seconds, the unit stops with the simultaneous glowing of the **same LED** to monitor the **BIN FULL** situation (Fig.6).



Take the hand out from the ice level control sensors to allow the resumption of the light beam.

After approximately 6 seconds the ice maker resume its operation with the immediate glowing of the **FIRST YELLOW LED** indicating **UNIT IN OPERATION** and the extinguishing of the "**BIN FULL**" **YELLOW LED**.

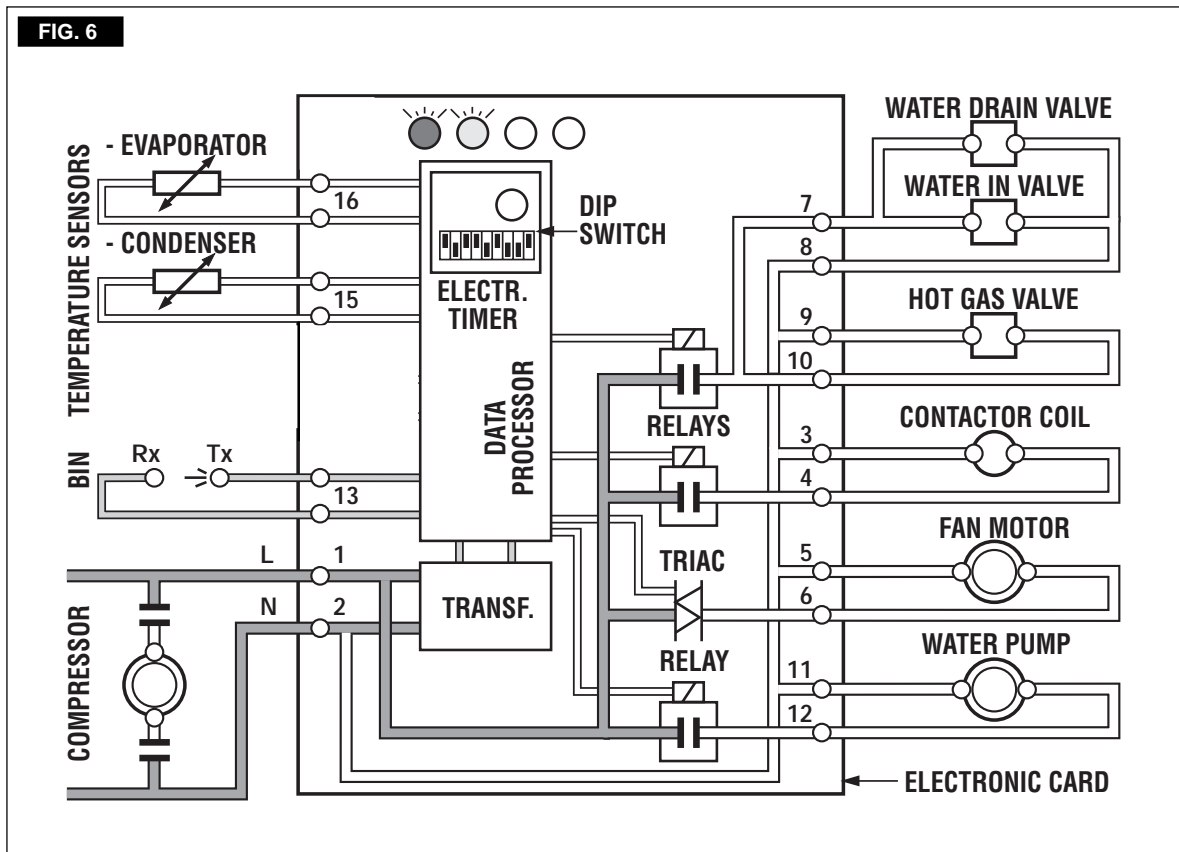

NOTE. The **ICE LEVEL CONTROL (INFRARED SYSTEM)** is independent of the temperature however, the reliability of its detection can be affected by external light radiations or by any sort of dirt and scale sediment which may deposit directly on the light source and on the receiver. To prevent any possible ice maker malfunction, due to negative affection of the light detector, it is advisable to locate the unit where it is **not reached by any direct light beam** or light radiation, also it is recommended to keep the bin door constantly closed and to follow the instructions for the **periodical cleaning of the light sensor elements** as detailed in the **MAINTENANCE AND CLEANING PROCEDURES**.
Its sensivity can be adjusted by turning the IR trimmer.

M. Remove, if fitted, the refrigerant service gauges and re-fit the unit service panels previously removed.

N. Instruct the owner/user on the general operation of the ice machine and about the cleaning and care it requires.

PRINCIPLE OF OPERATION

How it works

In the **SCOTSMAN** cube ice makers the water used to make the ice is kept constantly in circulation by an electric water pump which primes it to the spray system nozzles from where it is diverted into the inverted mold cups of the evaporator. A small quantity of the sprayed water freezes into ice; the rest of it cascades by gravity into the sump assembly below for recirculation.

FREEZING CYCLE

The hot gas refrigerant discharged out from the compressor reaches the condenser where, being cooled down, condenses into liquid. Flowing into the liquid line it passes through the drier filter, then it goes all the way through the capillary tube where, due to the heat exchanging action, it loses some of its heat content so that its pressure and temperature are lowered as well.

Next the refrigerant enters into the evaporator serpentine (which has a larger I.D. than the capillary) and starts to boil off; this reaction is emphasized by the heat transferred by the sprayed water.

The refrigerant then increases in volume and changes entirely into vapor.

The vapor refrigerant then passes through the suction accumulator (used to prevent that any small amount of liquid refrigerant may reach the compressor) and through the suction line. In both the accumulator and the suction line it exchanges heat with the refrigerant flowing into the capillary tube (warmer), before to be sucked in the compressor and to be recirculated as hot compressed refrigerant gas.

The freezing cycle is controlled by the evaporator temperature sensor (which has its probe in contact with the evaporator serpentine) that determines the length of its first portion of the cycle. When the temperature of the evaporator serpentine drops to a pre-set value (small Red LED ON steady) the evaporator sensor probe changes its electrical resistance allowing a low voltage current (15 volts) to flow to the P.C. BOARD which in turn activates an electronic timer.

The timer, which is built-in the P.C. BOARD, takes over from the evaporator temperature sensor, the control of the freezing cycle up to its completion.

NOTE. The change of the electric potential of the evaporator sensor with the consequent activation of the timer (Time mode) is signalled by the glowing-up of the RED LED located in the front of the P.C. BOARD.

ATTENTION. In case, after 15 minutes from the beginning of the freezing cycle, the temperature of the evaporator sensor probe is higher than 0° C (32°F) - small Red LED still OFF - (shortage of refrigerant, inoperative hot gas valve, etc.) the P.C. BOARD switch OFF immediately the unit with the simultaneous blinking of the WARNING RED LED.

The length of this timed portion of the freezing cycle is pre-fixed and related to the setting of the first four DIP SWITCH keys.

The DIP SWITCH keys setting is made in consideration of the type of condenser used and size of ice cubes.

In Table B are indicated the various lengths of the timed portion of freezing cycle in relation to the different combinations of the DIP SWITCH KEYS.

In Table A herebelow are illustrated the DIP SWITCH keys combinations for the different models and versions as they are set in the factory.

The electrical components in operation during the freezing cycle are:

COMPRESSOR

FAN MOTOR (in air cooled version)

WATER PUMP

CONTACTOR COIL (EC 125-175 only)

and during the second phase of freezing cycle (Time mode) they are joined by the

ELECTRONIC TIMER

The refrigerant head pressure, in the course of the freezing cycle, ranges between 8.5 and 9.5 bars (110÷130 psig) in the air cooled version,

TAB. A DIP SWITCH FACTORY SETTING COMBINATIONS (PER MODEL AND VERSION)										
DIP SWITCH	FREEZING CYCLE				DEFROST CYCLE			W. PUMP	15/30"	AIR/WATER
	1	2	3	4	5	6	7			
ACM 45-55-85-125-175 A	ON	ON	OFF	ON	ON	OFF	ON	ON	OFF	ON
ACM 45-55-85-125-175 W	ON	ON	OFF	ON	ON	OFF	ON	ON	OFF	OFF
ACM 105 A	ON	ON	OFF	ON	ON	ON	ON	ON	OFF	ON
ACM 105 W	ON	ON	OFF	ON	ON	ON	ON	ON	OFF	OFF

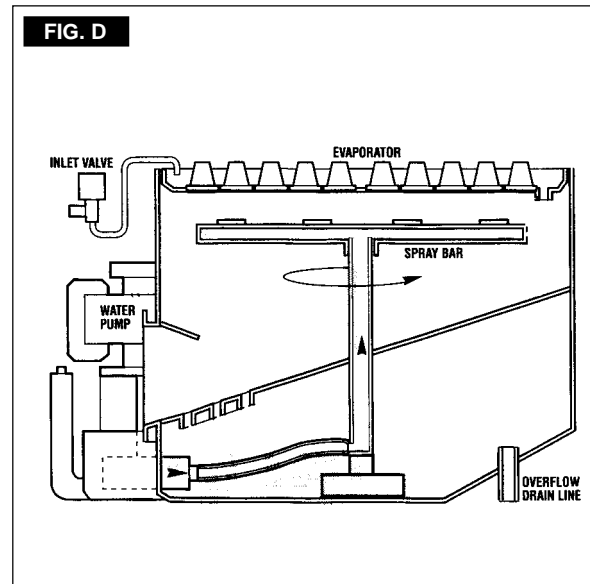
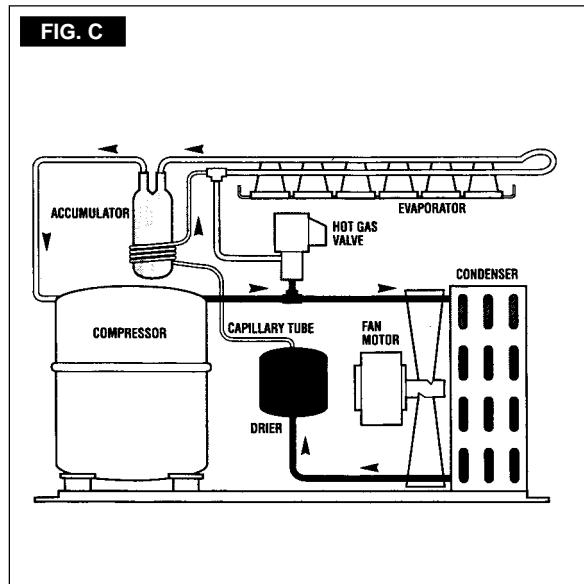
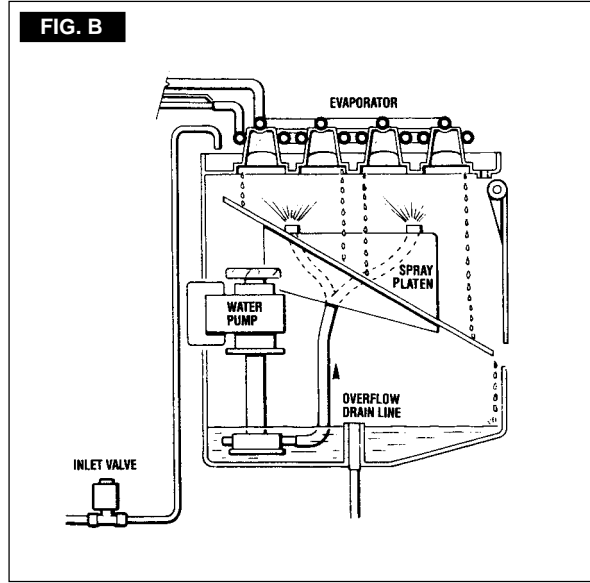
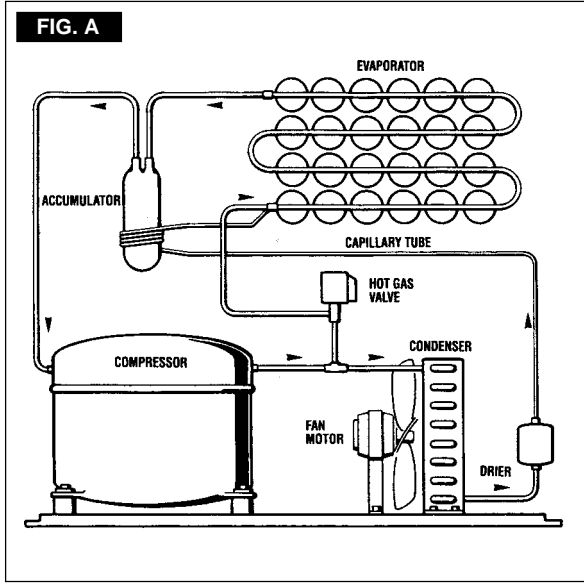

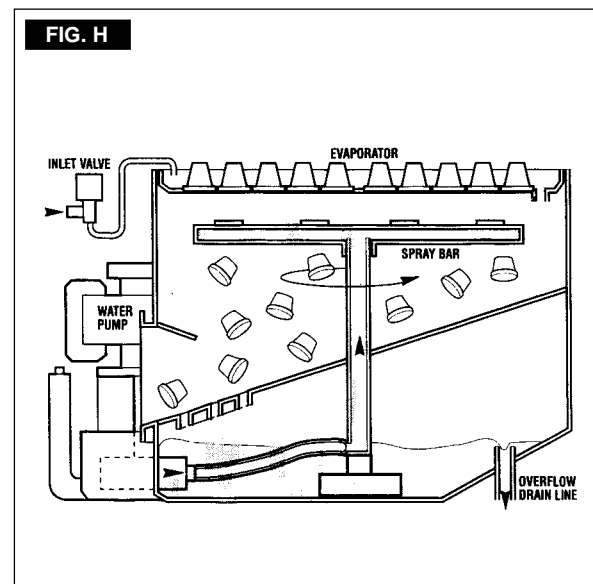
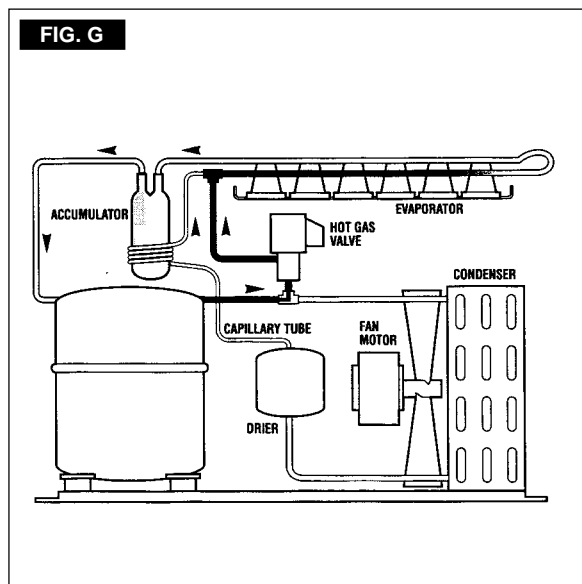
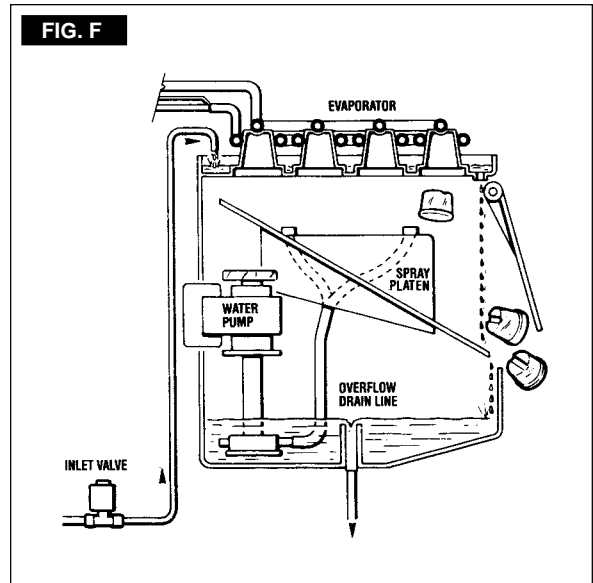
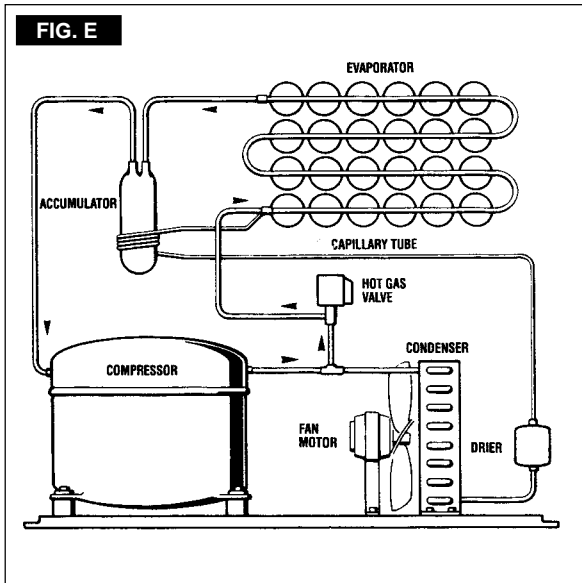

and between 9.5 and 10.5 bar (135÷150 psig) in the water cooled version, being controlled by the temperature sensor probe located within the condenser fins (air cooled version) or, on the condenser tube coil (water cooled version). On the air cooled version, the condenser temperature sensor, when senses a rising of the condenser temperature beyond the pre-fixed limit, changes its electrical resistance and transmits a low voltage power flow to the Micro Processor of P.C. BOARD which in turn energizes, through a **TRIAC**, the **FAN MOTOR**. When the opposite situation occurs, i.e. the condenser temperature gets below the pre-fixed limit, the temperature sensor changes again its electrical resistance reducing therefore the current flow to the P.C. BOARD to cause the fan motor temporary cut-off.

NOTE. In case the condenser temperature probe senses that the condenser temperature has risen to 70°C (160°F) - on air cooled versions - or 60°C (140°F) - on water cooled versions - for one of the following reasons:
CLOGGED CONDENSER (Air cooled version)
INSUFFICIENT FLOW OF COOLING WATER (Water cooled version)
FAN MOTOR OUT OF OPERATION (Air cooled version)
AMBIENT TEMPERATURE HIGHER THEN 40°C (100°F)
 it causes the total and immediate **SHUT-OFF** of the machine in order to prevent the unit from operating in abnormal and dangerous conditions.
 When the ice maker stops on account of this protective device, there is a simultaneous glowing of the **RED LED**, warning the user of the **Hi Temperature** situation.
 After having eliminated the source of the condenser hi-temperature, to restart the machine it is necessary to unplug (wait few seconds) and plug in again the unit. The ice machine resumes its normal operation by going through the 5 minutes water filling phase.

At the start of the freezing cycle the refrigerant suction or lo-pressure lowers rapidly to 1 bar - 14 psig then it declines gradually - in relation with the growing of the ice thickness - to reach, at the end of the cycle, approx. 0÷0,1 bar - 0÷0,3 psig with the cubes fully formed in the cup molds. The total length of the freezing cycle ranges from 20 to 25 minutes.

DEFROST OR HARVEST CYCLE (Fig.E and G)

As the electronic timer has carried the system throughout the second phase of freezing cycle, the defrost cycle starts.

ATTENTION. In case the unit is able to reach 0°C (32°F) evaporating temperature within 15 minutes, but after 45 minutes from the beginning of the freezing cycle it has not yet reached the evaporator temperature of -15°C (5°F) the machine goes straight into the defrost cycle omitting the timed portion of the freezing cycle relied to the setting of the first four DIP SWITCHES.

NOTE. The length of the defrost cycle (not adjustable) is related to the length of the second phase of freezing cycle T2. (Time to drop the evaporating temperature from 0°C (32°F) - small Red LED blinking - to -15°C (5°F) small Red LED ON steady.

The electrical components in operation during this phase are:

- COMPRESSOR**
 - CONTACTOR COIL** (EC 125-175 only)
 - WATER INLET VALVE**
 - HOT GAS VALVE**
 - WATER DRAIN VALVE**
 - and the
 - WATER PUMP**
- on the first 15 seconds.

The incoming water, passing through the water inlet valve and the flow control, runs over the evaporator platen and then flows by gravity through the dribbler holes down into the sump/reservoir. (Fig. F and H)

The water filling the sump/reservoir forces part of the surplus water from the previous freezing cycle to go out to the waste through the overflow pipe. This overflow limits the level of the sump water which will be used to produce the next batch of ice cubes.

Meanwhile, the refrigerant as hot gas, discharged from the compressor, flows through the hot gas valve directly into the evaporator serpentine bypassing the condenser.

The hot gas circulating into the serpentine of the evaporator warms up the copper molds causing the defrost of the ice cubes. The ice cubes, released from the cups, drop by gravity onto a slanted cube chute, then through a curtained opening they fall into the storage bin.

NOTE. The length of the defrost cycle, factory set, changes in accordance with the duration of the second portion of the freezing cycle (Time T2) that is related to the ambient temperature.

At the end of the defrost cycle, the hot gas valve, the water inlet valve and the water drain valve close and the machine starts again a new freezing cycle.

PWD SYSTEM

COMPONENTS

The components of the Pump Out Water Drain System are

- Sealed water tank
- Special Interface PC Board & Sensor
- Special Sealed Water Pump
- Check Valve

OPERATION

All water coming from the overflow, the purge valve and the melted ice is collected inside the Sealed Water Reservoir.

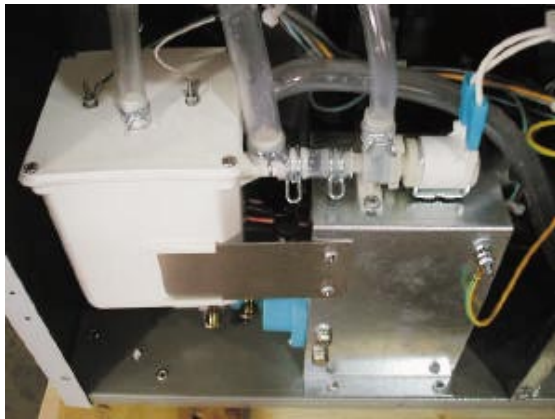

As soon as the water into the Sealed Water Reservoir reaches the maximum level, the two metal pins close the electrical contact through the water, transmitting a low voltage current to the Special Interface PC Board.

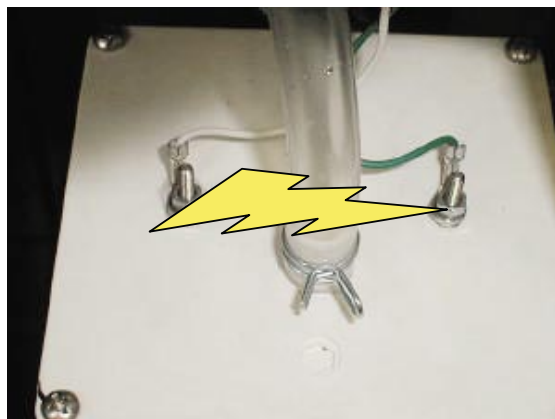

The interface PC Board activates the Water Drain Pump for 8 seconds pumping out most

of the water contained into the Sealed Water Reservoir.



The water can be pumped out up to 1.5 m rise or

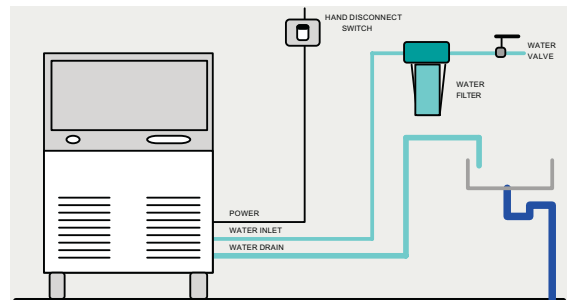

to 30 m on horizontal length.

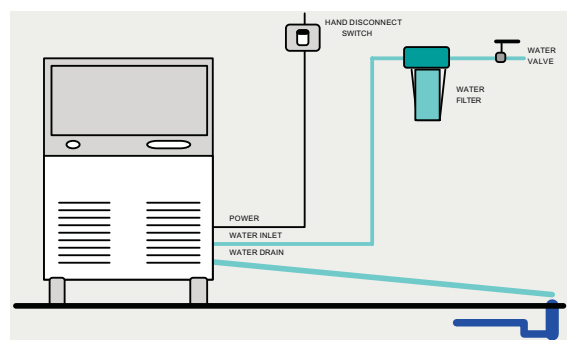

A Check Valve, located on the water drain hose, prevents the coming back of the discharged water.

The Special Interface PC Board is equipped with a "trimmer" that can be adjusted accordingly to the different electrical conductivity of the water.

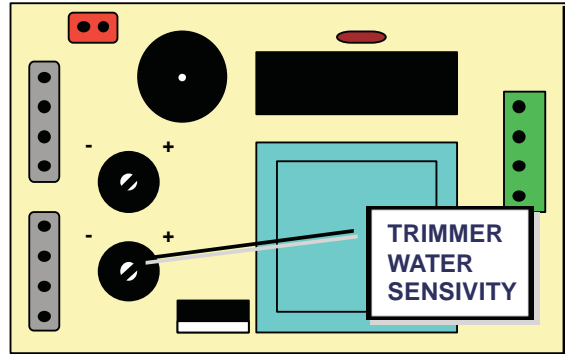

SCHEMATIC SYSTEM

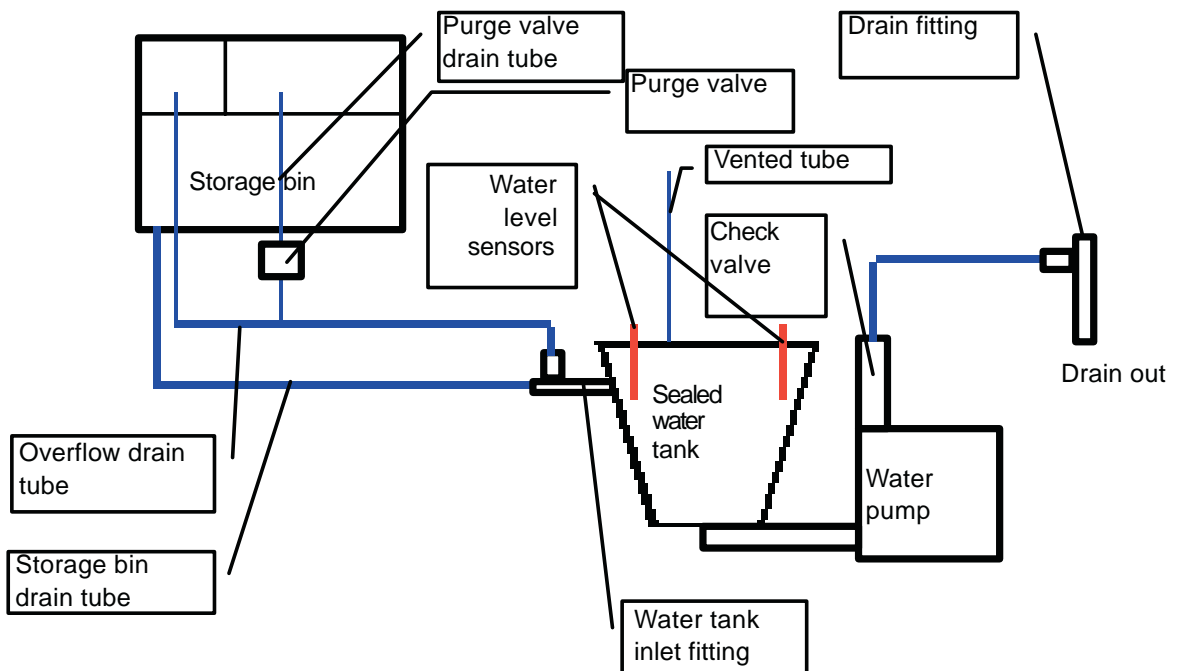

OPERATION - CONTROL SEQUENCE

At the start of freezing cycle the evaporator temperature sensor controls the length of the first part of the freezing cycle. As it reaches a predetermined temperature it supplies a low voltage current to the P.C. BOARD in order to activate the electronic timer which takes over the control of the freezing cycle for a pre-fixed time according to the DIP SWITCH keys setting (see Tab. B).

NOTE. The evaporator temperature sensor, factory pre-set, is the same for all the models and is not adjustable in the field.

Once completed the timed portion of the freezing cycle the system goes automatically into the defrost cycle which has also a pre-fixed length. At completion of the defrost cycle the P.C. BOARD command the unit to start again a new freezing cycle.

OPERATION - ELECTRICAL SEQUENCE

The following charts illustrate which switches and which components are ON or OFF during a particular phase of the icemaking cycle. Refer to the wiring diagram for a reference.

BEGINNING FREEZE

Electrical components (Loads)	ON	OFF
Compressor	●	
Fan Motor (Air cooled only) and TRIAC	●	
Hot Gas Valve		●
Water Inlet Valve		●
Water Drain Valve		●
P.C.Board Relay 1 Coil		●
P.C.Board Relay 2 & 3 Coil	●	
Water Pump	●	
Contactor Coil (EC 125-175 only)	●	
P.C.B. Timer		●

Electronic Controls & Sensors	ON	OFF
Evaporator Sensor		●
Condenser Sensor	●	
Ice Level Control	●	

TIMED FREEZE

Electrical components (Loads)	ON	OFF
Compressor	●	
Fan Motor (Air cooled only) and TRIAC	●	●
Hot Gas Valve		●
Water Inlet Valve		●
Water Drain Valve		●
P.C.Board Relay 1 Coil		●
P.C.Board Relay 2 & 3 Coil	●	
Water Pump	●	
Contactor Coil (EC 125-175 only)	●	
P.C.B. Timer	●	

Electronic Controls & Sensors	ON	OFF
Evaporator Sensor	●	
Condenser Sensor	●	●
Ice Level Control	●	

HARVEST (Drain portion - first 15 sec.)

Electrical components (Loads)	ON	OFF
Compressor	●	
Fan Motor (Air cooled only)and TRIAC		●
Hot Gas Valve	●	
Water Inlet Valve	●	
Water Drain valve	●	
P.C.Board Relay 1 & 2 Coil	●	
P.C.Board Relay 3 Coil	●	
Water Pump	●	
Contactor Coil (EC 125-175 only)	●	
P.C.B. Timer	●	

Electronic Controls & Sensors	ON	OFF
Evaporator Sensor		●
Condenser Sensor		●
Ice Level Control	●	

HARVEST (Water filling portion)

Electrical components (Loads)	ON	OFF
Compressor	●	
Fan Motor (Air cooled only)and TRIAC		●
Hot Gas Valve	●	
Water Inlet Valve	●	
Water Drain valve	●	
P.C.Board Relay 1 & 2 Coil	●	
P.C.Board Relay 3 Coil		●
Water Pump		●
Contactor Coil (EC 125-175 only)	●	
P.C. Board Timer	●	

Electronic Controls & Sensors	ON	OFF
Evaporator Sensor		●
Condenser Sensor		●
Ice Level Control	●	

OPERATING CHARACTERISTICS

Freeze Cycle

Average Discharge
Pressure A/C: 9.5÷8.5 bar (130÷110 psig)

Average Discharge
Pressure W/C: 10.5÷9.5 bar (150÷135 psig)

Suction Pressure
End Freeze Cycle: 0 ÷ 0.1 bar (0 ÷ 1 psig)

REFRIGERANT METERING DEVICE:

capillary tube

REFRIGERANT CHARGE (R 134 A)

	Air cooled	Water cooled
EC 45	250 gr (9.0 oz.)	250 gr (9.0 oz.)
EC 55	260 gr (9.3 oz.)	250 gr (9.0 oz.)
EC 85	290 gr (10.2 oz.)	250 gr (9.0 oz.)
EC 105	320 gr (11.0 oz.)	250 gr (9.0 oz.)
EC 125	450 gr (16.0 oz.)	300 gr (10.6 oz.)
EC 175	450 gr (16.0 oz.)	330 gr (11.6 oz.)

COMPONENTS DESCRIPTION

A. EVAPORATOR TEMPERATURE SENSOR

The evaporator temperature sensor probe, located in contact with the evaporator serpentine, detects the dropping of the evaporator temperature during the freezing cycle and signals it by supplying a current flow to the micro processor of P.C. BOARD.

According to the current received is energized the small Red LED of the PC Board (blink or steady). When steady, the micro processor supplies power to the electronic timer built into the P.C. BOARD so that it takes control of the last portion of freezing cycle.

The length of the timed phase is pre-fixed by the setting of the keys 1, 2, 3 and 4 of the DIP SWITCH.

NOTE. Whenever, after 15 minutes from the beginning of the freezing cycle, the evaporating temperature have not yet reached the value of 0°C (32°F) - small Red LED OFF - the P.C.Board switches OFF the machine with the BLINKING of WARNING RED LED.

B. CONDENSER TEMPERATURE SENSOR

The condenser temperature sensor probe, located within the condenser fins (air cooled version) or in contact with the tube coil (water cooled version) detects the condenser temperature variations and signals them by supplying current, at low voltage, to the P.C. BOARD. In the air cooled versions, in relation to the different current received, the micro processor of the P.C. BOARD supplies, through a TRIAC, the power at high voltage to the fan motor so to cool the condenser and to reduce its temperature. In case the condenser temperature rises and reaches 70°C (160°F) - on air cooled models - or 60°C (140°F) - on water cooled models - the current arriving to the micro processor is such to cause an immediate and total stop of the machine operation.

C. ICE BIN LEVEL LIGHT CONTROL

The electronic ice bin level control, located into the storage bin, has the function to stop the operation of the ice machine when the light beam between the light source and the sensor is interrupted by the ice cubes stored into the bin. When the light beam is interrupted the Bin Full YELLOW LED starts to blink; in case the light beam is constantly interrupted for more than 60 seconds, the ice machine stops with the glowing-up of the **Bin Full YELLOW LED** to monitor the situation of ice bin full.

The 60 seconds of delay prevent that an ice scoop movement or the ice dropping through the ice chute (interrupting for a while the light beam) can stop the operation of the unit.

Six seconds after the scoop out of the ice (with the resumption of the light beam between the two infrared sensor of ice level control) the ice machine restarts again with the extinguishing of the YELLOW LED.

printed circuits one at high and the other at low voltage integrated with two fuses one on power in (32mA) and one on power out (6.3 A), of four aligned **LEDS** monitoring the operation of the machine, of one extra monitoring **RED LED** (blink 0°C - steady - 15°C), of one **DIP SWITCH** with ten keys, of one push button, of input terminals for the leads of the sensor probes and input and output terminals for the leads of the ice maker electrical wires.

The P.C. BOARD is the brain of the system and it elaborates, through its micro processor, the signals received from the three sensors in order to control the operation of the different electrical components of the ice maker (compressor, water pump, solenoid valves, etc.).

D. P.C. BOARD (Data processor)

The **P.C. BOARD**, fitted in its plastic box located in the front of the unit, consists of two separated

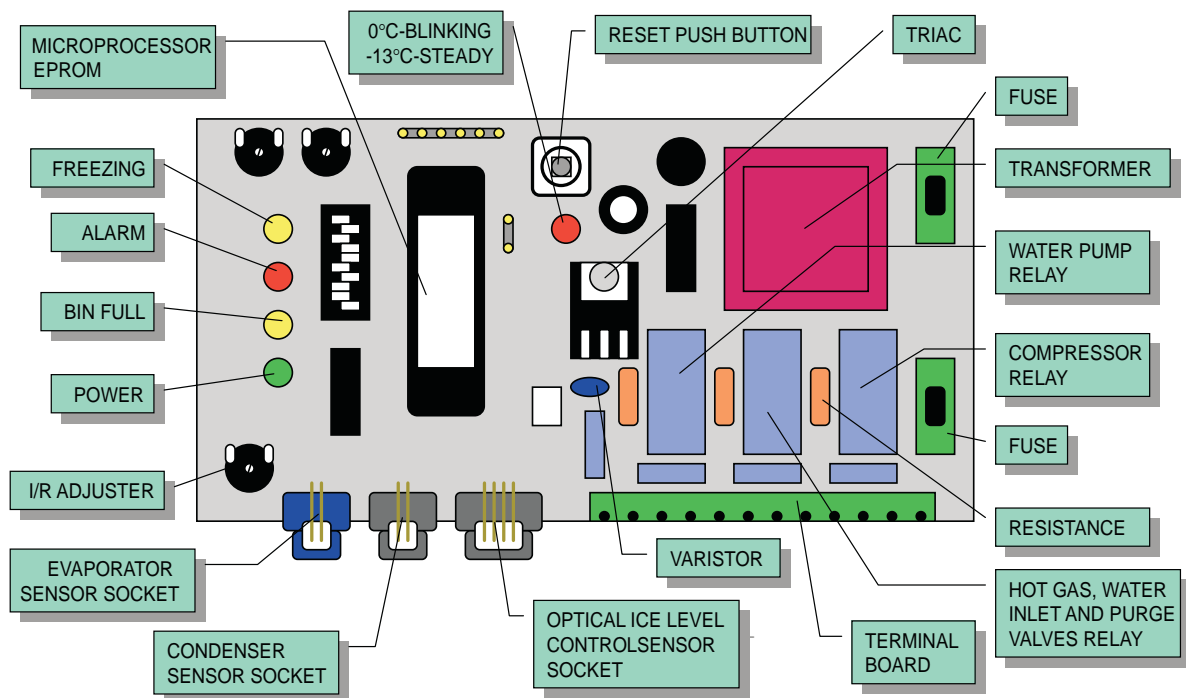

E. PUSH BUTTON OPERATION

DURING WATER FILLING PHASE

- Push for more then 2" but less then 5" the machine enters in Cleaning Mode
- Push for more then 5" the machine by-pass the Water Filling Phase

DURING FREEZING/HARVEST CYCLE

- Push for more then 5" during the Freezing cycle the machine goes immediately into Harvest
- Push for more then 5" during the Harvest cycle the machine enters immediately in the Freezing cycle

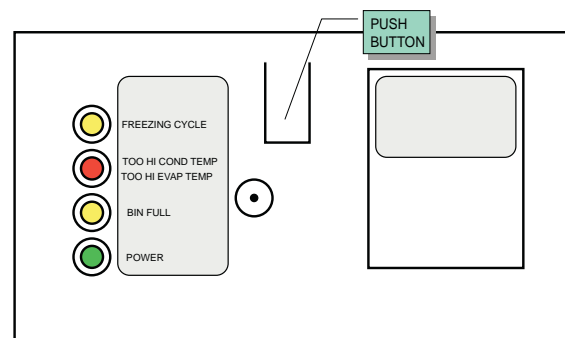

The length of Harvest is equal to:

- 35" if Push Button is activated before -15°C evaporating temperature LED activation
- As per Harvest cycle chart, if Push Button is activated after -15°C evaporating temperature LED activation (Red LED inside PC Board ON steady)

F. LED MEANING

GREEN LED ON
Unit under power

YELLOW BIN FULL LED ON
Unit shut-OFF at storage bin full
YELLOW BIN FULL LED BLINKING
Infrared beam break out

RED ALARM LED ON

Too hi condensing temperature

RED ALARM LED BLINKING

Too hi evaporating temperature

YELLOW FREEZING CYCLE ON

Unit in freezing cycle mode

YELLOW FREEZING LED AND RED ALARM LED ON

Condenser sensor out of order

YELLOW FREEZING LED AND RED ALARM LED BLINKING

Evaporator sensor out of order

G. DIP SWITCH

The P.C.BOARD which controls the entire operation of the ice maker, has a **DIP SWITCH with ten switching keys** which allow to set up the micro processor program in order to extend or to shorten the length of freezing cycle in relation to the different model and versions of ice machines.

The DIP SWITCH first four keys setting determines the length of the 2nd phase of freezing cycle (controlled by the electronic timer) as detailed in the table B.

TAB. B		LENGTH OF TIMED PORTION OF FREEZING CYCLE ACCORDING TO THE DIP SWITCH SETTING COMBINATIONS								
		1	2	3	4					
1	ON OFF	■	■	■	■					25 min.
2	ON OFF	■	■	■	■					23 min.
3	ON OFF	■	■	■	■					21 min.
4	ON OFF	■	■	■	■					19 min.
5	ON OFF	■	■	■	■					17 min.
6	ON OFF	■	■	■	■					15 min.
7	ON OFF	■	■	■	■					13 min.
		1	2	3	4					
8	ON OFF	■	■	■	■					11 min.
9	ON OFF	■	■	■	■					9 min.
10	ON OFF	■	■	■	■					7 min.
11	ON OFF	■	■	■	■					5 min.
12	ON OFF	■	■	■	■					3 min.
13	ON OFF	■	■	■	■					1 min.

The DIP SWITCH keys 5 & 6 setting determines the length of the defrost cycle according to the size of the cubes (Large or Medium) as per the following setting:

- ON ON : A
- ON OFF : B
- OFF OFF : C
- OFF ON : D

It is not possible to modify the length of the defrost cycle (factory setting).

LENGTH OF HARVEST CYCLE ACCORDING TO THE TIME TO DROP THE EVAP. TEMPERATURE FROM 0°C TO -15°C

LENGTH HARVEST CYCLE	PROGRAMS			
	A	B	C	D
180"	Upto 6'30"	***	Upto 9'30"	Upto 3'30"
165"	6'30"-7'	Upto 3'	9'30"-10'	3'30"-4'
150"	7'-8'	3'-3'15'	10'-11'	4'-4'30"
135"	8'-9'	3'15"-3'30"	11'-12'	4'30"-5'
120"	9'-10'30"	3'30"-4'30"	12'-13'30"	5'-5'30"
105"	10'30"-12'	4'30"-6'	13'30"-15'	5'30"-6'
90"	>12'	>6'	>15'	>6'

The 7th D.S. key is not used in this release of the P.C. BOARD.

The 8th key allows the operation of the water pump even during the defrost cycle, as required when it is necessary to drain out the remaining water from the sump.

The 9th key is used to supply power to the water pump for the first **15 seconds** of the defrost cycle - **position OFF** - or for the first **30 seconds** - **position ON**.

The 10th key is used to modify the CUT-OUT condensing temperature **from 70°C (160°F)** for the water cooled versions - **ON position** - to **60°C (140°F)** - **OFF position** - for the air cooled versions.

H. WATER SPRAY SYSTEM

Through its nozzles, the water pumped, is sprayed in each individual cup to be frozen into ice. It consists of one spray tube where are located several spray nozzles.

I. WATER PUMP

The water pump operates continually throughout the freezing cycle and on the first 15 or 30 seconds of the defrost cycle so to such the remaining water from the sump tank (reach in mineral salts) and drain it out.

During the freezing cycle the pump primes the water from the sump to the spray system and through the spray nozzles sprays it into the inverted cup molds to be frozen into crystal clear ice cubes.

It is recommended that the pump motor bearings be checked at least every six months.

J. WATER INLET SOLENOID VALVE - 3/4 MALE FITTING (Water cooled version)

A special water inlet solenoid valve with one inlet and two outlets (one for condenser and the second for the production of ice) is used on water cooled version.

An automatic hi pressure control activates the second coil of the water inlet solenoid valve so to supply a metered amount of water to the condenser and drop down its temperature and pressure.

K. HOT GAS SOLENOID VALVE

The hot gas solenoid valve consists basically in two parts: the valve body and the valve coil. Located on the hot gas line, this valve is energized through the micro processor of P.C. BOARD during the defrost cycle as well as during the water filling phase.

During the defrost cycle the hot gas valve coil is activated so to attract the hot gas valve piston in order to give way to the hot gas discharged from compressor to flow directly into the evaporator serpentine to defrost the formed ice cubes.

L. FAN MOTOR (Air cooled version)

The fan motor is controlled through the P.C. BOARD and the TRIAC by the condenser temperature sensor. Normally it operates only during the freezing cycle to draw cooling air through the condenser fins. In the second part of the freezing cycle, the fan motor can run at intermittance as the condenser pressure must be kept between two corresponding head pressure values.

M. COMPRESSOR

The hermetic compressor is the heart of the refrigerant system and it is used to circulate and retrieve the refrigerant throughout the entire system. It compresses the low pressure refrigerant vapor causing its temperature to rise and become high pressure hot vapor which is then released through the discharge valve.

N. HI PRESSURE CONTROL - EC 45-55-85-105 (Water cooled version)

Used only on the water cooled versions it operates to keep between 9.5 and 10.5 bars (135 ÷ 150 psig) the hi-side or discharge pressure of the refrigerant system by energizing the coil of the water inlet solenoid valve that control the cooling water flow to the condenser.

O. WATER REGULATING VALVE - EC 125-175 (Water cooled version)

This valve controls the head pressure in the refrigerant system by regulating the flow of water going to the condenser.

As pressure increases, the water regulating valve opens to increase the flow of cooling water.

P. CONTACTOR - EC 125-175

Placed outside of the control box it is controlled by the P.C. BOARD in order to close or open the electrical circuit to the compressor.

Q. WATER DRAIN SOLENOID VALVE

The water drain solenoid valve, electrically connected in parallel to the water inlet and to the hot gas solenoid valves, is energized for all the length of the defrost cycle.

By means of the water pump, that remains energized for 15 seconds at the beginning of the defrost cycle, it allows the drain out of all remaining water (rich of minerals deposited during the previous freezing cycle) from the sump tank.

By doing so it allows to the ice maker to make every new freezing cycle with new fresh water, avoiding thereby the accumulation of sediments and scales, which soon or later will cause the partial or total clogging of the water system on the unit.

R. SEALED WATER RESERVOIR

Located on the bottom side of the unit, it is used to collect all water coming from the:

- Overflow
- Water Drain Valve
- Storage bin

On its top cover are secured two metal pins (Water Level Sensor) connected to the PWD PC Board.

S. PWD PC BOARD

Located on the front side of the machine, it is used to energise the Water Drain Valve any time the level of the water into the Sealed water Reservoir reaches the upper metal pins (low power electrical circuit closed through the water). The water pump is kept energised by the PWD PC Board according to the setting of its trimmer.

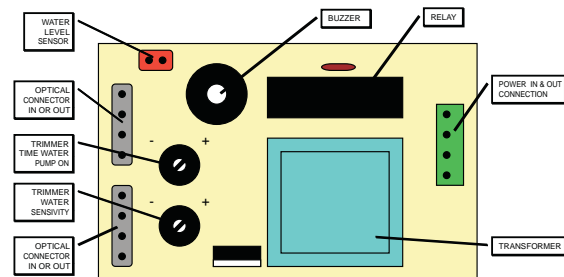

A second trimmer is used to increase the signal (low power current) received by the water level sensor of the Sealed Water Reservoir in order to overcome the problem of low electrical conductivity of very soft water.

WARNING: to assure the correct operation of the Water level sensors, the water must have a minimal electrical of 10 µS.

A Buzzer, on the PWD PC Board, is used to alert the end user in case the water level sensor transmit the signal to the PWD PC Board for more then 5 minutes continuously so to avoid any possibility of water overflowing. In the meantime the Main PC Board will switch OFF the entire machine at Storage Bin Full.

T. WATER DRAIN PUMP

Placed beside the Sealed Water Reservoir is used to pump out the water contained into the tank. It is energised, by the PWD PC Board, for just few seconds.

U. CHECK VALVE

Placed on the discharge hose of the water pump, it prevents the coming back of the pumped out water.

ADJUSTMENT PROCEDURES

A. ADJUSTMENT OF THE CUBE SIZE

CAUTION. Before performing actual adjustment of the cube size, check other possible causes for cube size problems, refer to the Service Diagnosis Section for problem review and analysis. Do not perform any adjustment till the icemaking system has progressed through several complete freezing and harvest cycle, to observe size and quality of ice cubes and whether or not the cube size problem exists.

I. If the cubes are shallow size (Indentation is too deep) probably the length of the second phase of the freezing cycle is too short so, to extend such length you have to:

1. Locate the DIP SWITCH on the front of the P.C.Board.
2. Take note of the combination of the first four DIP SWITCH KEYS and check the corresponding length of freezing cycle 2nd phase on Table B.
3. Set the same DIP SWITCH KEYS to correspond to the prior combination shown on Table B which allow an extension of two more minutes of the length of the freezing cycle.
4. Observe the ice cubes in the next two harvests and eventually repeat steps 2 and 3 above until proper ice cubes size is achieved. See figure.

II. If the cubes are oversize size (Indentation is too full) probably the length of the second phase of the freezing cycle is too long. To shorten such length you have to:

1. Locate the DIP SWITCH on the front of the P.C.Board.
2. Take note of the combination of the first four DIP SWITCH KEYS and check the corresponding length of freezing cycle 2nd phase on Table B.
3. Set the same DIP SWITCH KEYS to correspond to the next combination shown on Table B which allow a reduction of two minutes of the length of the freezing cycle.
4. Observe the ice cubes in the next two harvests and eventually repeat steps 2 and 3 above until proper ice cubes size is achieved. See figure.

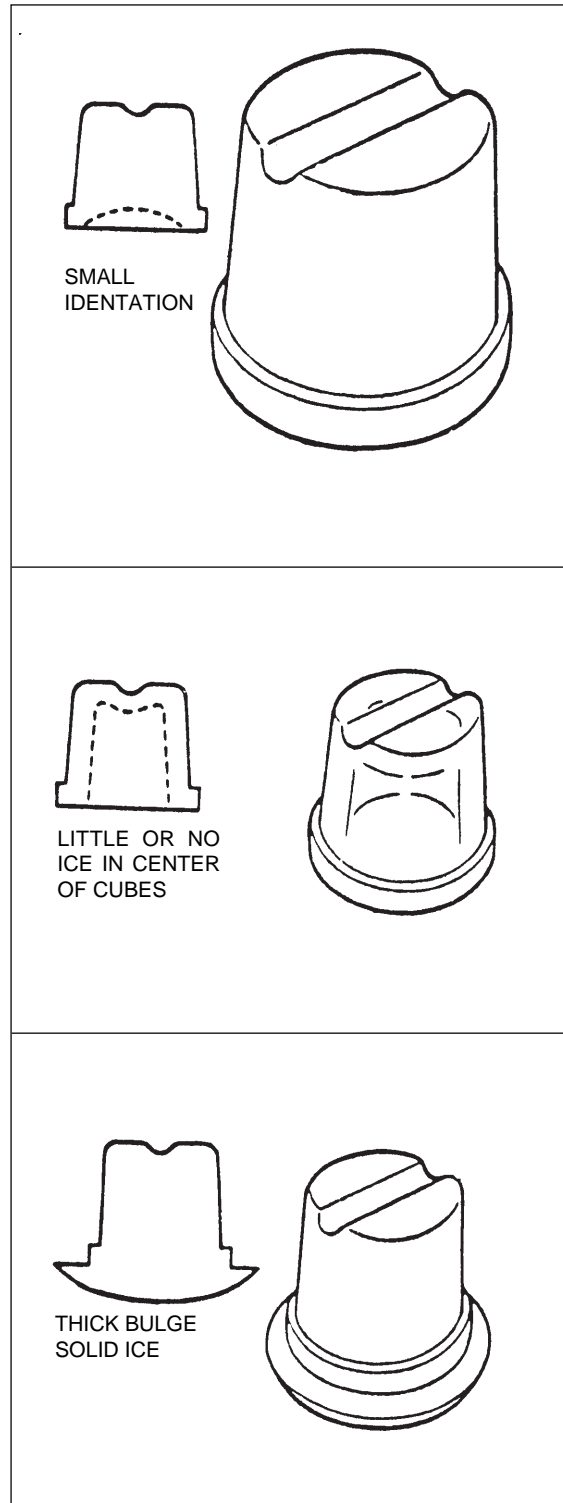

WIRING DIAGRAM

EC 45/55/85/105 AIR & WATER COOLED 230/50-60/1

- R - RED
- O - ORANGE
- B - WHITE
- G - GREY
- N - BLACK
- A - BLUE
- M - BROWN
- GV - YELLOW GREEN

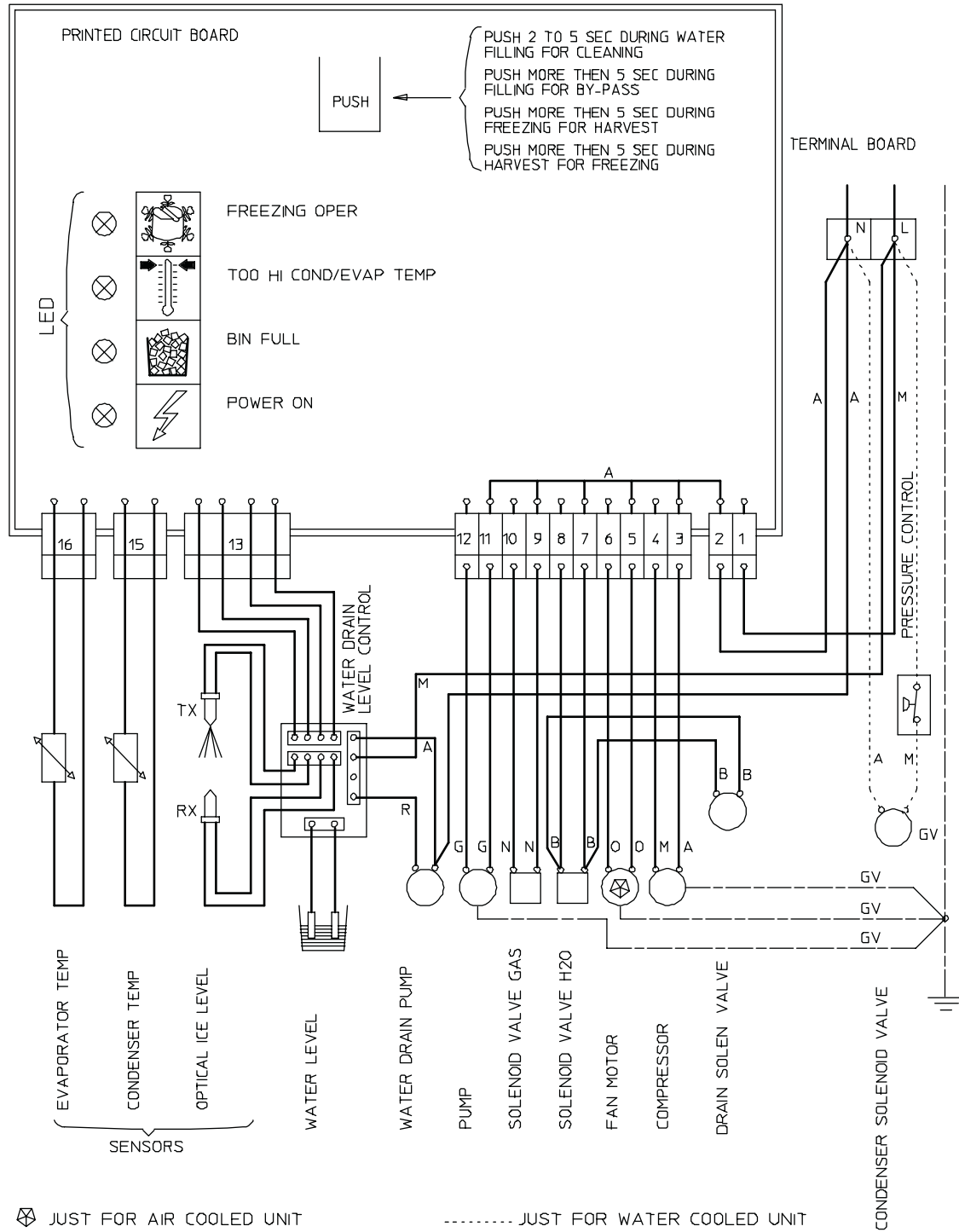

WIRING DIAGRAM EC 125/175 AIR & WATER COOLED 230/50-60/1

- R - RED
- O - ORANGE
- B - WHITE
- G - GREY
- N - BLACK
- A - BLUE
- M - BROWN
- GV - YELLOW GREEN

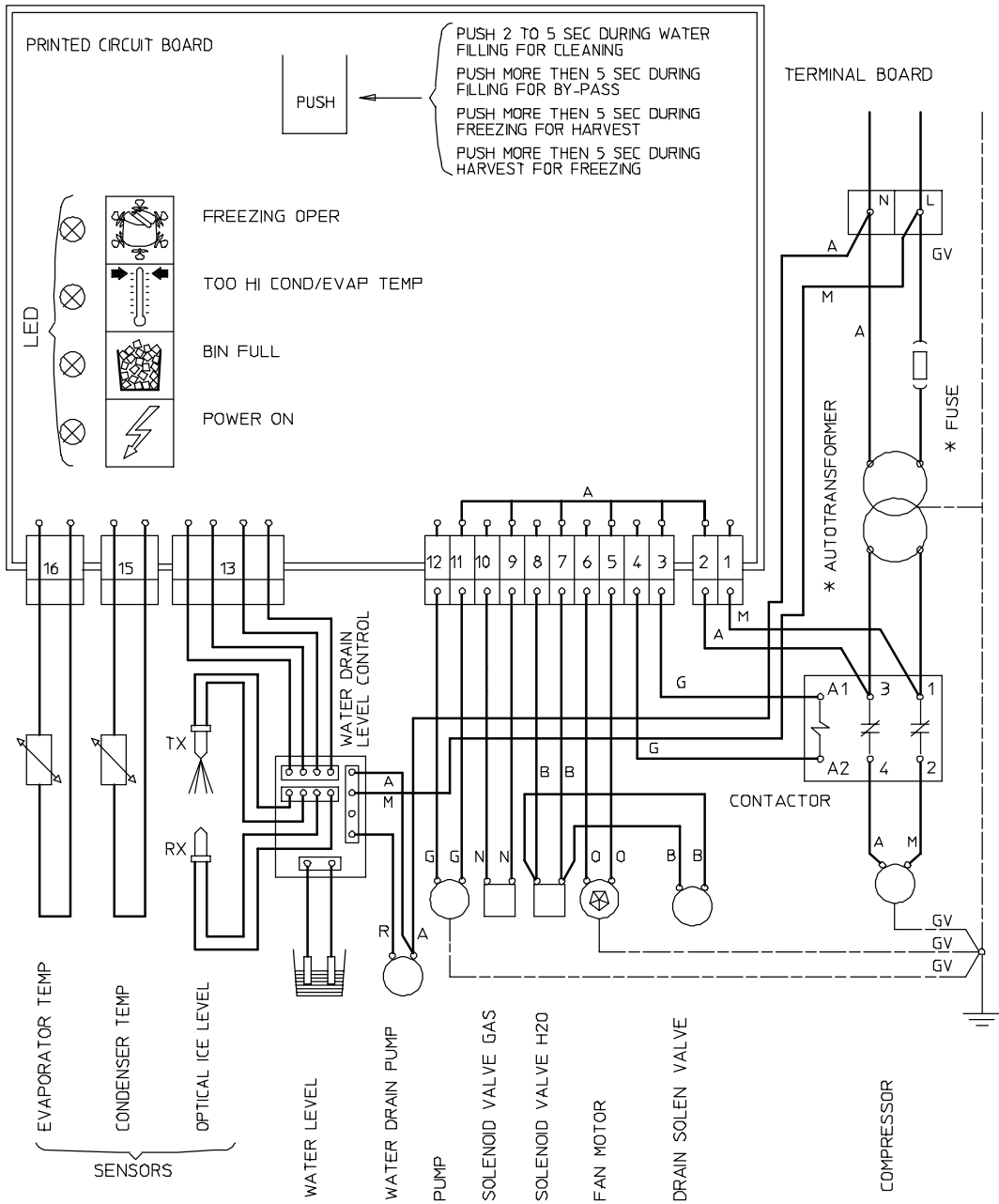

⊗ JUST FOR AIR COOLED UNIT

* USED ONLY UNIT AT 240V

SERVICE DIAGNOSIS

SYMPTOM	POSSIBLE CAUSE	SUGGESTED CORRECTION
Unit will not run (No warning LEDS glows)	Blown power in fuse in P.C.Board Main switch in OFF position Inoperative P.C.Board Loose electrical connections	Replace fuse & check for cause of blown fuse Turn switch to ON position Replace P.C.Board Check wiring
(Green LED-Power ON glows)	Blown power out fuse in P.C. Board	Replace fuse & check for cause of blown fuse
(Bin full LED glows)	Inoperative ice level control Inoperative P.C.Board	Clean or replace ice level control Replace P.C.Board
(Red-alarm LED glows)	High head pressure	Dirty condenser. Clean Inoperative fan motor. Replace Shortage of water (WC)
(Red-alarm LED blinks)	High evaporating temperature after 15 mins. beginning freeze	Hot gas valve leak - Replace it. Water inlet valve leak - Replace it. Short of refrigerant. Compressor cycles intermittently
(Freezing LED + Red-alarm LED glow)	Condenser sensor out of order	Replace it
(Freezing LED + Red-alarm LED blink)	Evaporator sensor out of order	Replace it
Compressor cycles intermittently	Low voltage Contactor with burnt contacts EC 125-175 only Non-condensable gas in system Compressor starting device with loose wires Mechanical problem	Check circuit for overloading Check voltage at the supply to the building. If low, contact the power company Replace it Purge the system Check for loose wires in starting device Replace compressor
Cubes too small	Freezing cycle too short Capillary tube partially restricted Moisture in the system Shortage of refrigerant	Review setting of DIP SWITCH keys Blow charge, add new gas & drier, after evacuating system with vacuum pump Same as above Check for leaks & recharge
Cloudy cubes	Shortage of water Dirty water supply Accumulated impurities	See remedies for shortage of water Use water softener or water filter Use SCOTSMAN Ice Machine cleaner

SERVICE DIAGNOSIS

SYMPTON	POSSIBLE CAUSE	SUGGESTED CORRECTION
Shortage of water	Water spilling out through curtain Water solenoid valve not opening Water leak in sump area Water flow control plugged Leak of water drain valve	Check or replace curtain Replace valve Locate and repair Replace water inlet valve Replace valve
Irregular cubes size & some cloudy	Some jets plugged Shortage of water Unit not level	Remove jet cover and clean See shortage of water Level as required
Cubes too large	Freezing cycle too long	Review setting of DIP SWITCH keys
Decreased ice capacity	Inefficient compressor Leaky water valve Non-condensable gas in system Poor air circulation or excessive hot location (Red-alarm LED glows) Overcharge of refrigerant Capillary tube partially restricted Hot gas solenoid valve leaking Short of refrigerant Discharge head pressure too high	Replace Repair or replace Purge the system Relocate the unit or provide for more ventilation Correct the charge. Purge off slowly Blow charge, add new gas & drier, after evacuating system with vacuum pump Replace valve Charge to data plate indication See incorrect discharge pressure
Poor harvest	Restriction in incoming water line Water inlet valve not opening Hot gas valve orifice restricted Clogged air vented holes in mold cups Discharge head pressure too low	Check water valve strainer and flow control. If necessary enlarge the flow control orifice Valve coil with open winding Replace valve Replace hot gas valve assy Clean out holes plugged See incorrect discharge pressure

SERVICE DIAGNOSIS

SYMPTON	POSSIBLE CAUSE	SUGGESTED CORRECTION
Unit won't harvest	Inoperative P.C.Board Hot gas valve not opening Water solenoid valve not opening	Replace P.C.Board Valve coil with open winding Replace valve Valve coil with open winding Replace valve
Incorrect discharge pressure	Inoperative condenser sensor Inoperative P.C.Board Water regulating valve misadjusted (EC 125-175 only)	Replace sensor Replace P.C.Board Adjust its setting stem
Excessive water in unit base	Water tubing leaking	Check. Tighten or replace

MAINTENANCE AND CLEANING INSTRUCTIONS

A. GENERAL

The periods and the procedures for maintenance and cleaning are given as guides and are not to be construed as absolute or invariable. Cleaning, especially, will vary depending upon local water and ambient conditions and the ice volume produced; and, each icemaker must be maintained individually, in accordance with its particular location requirements.

B. ICEMAKER

The following maintenance should be scheduled at least two times per year on these icemakers.

1. Check and clean the water line strainer.
2. Check that the icemaker is levelled in side to side and in front to rear directions.
3. Clean the water system, evaporator, bin and spray jets using a solution of SCOTSMAN Ice Machine Cleaner. Refer to procedure C cleaning instructions and after cleaning will indicate frequency and procedure to be followed in local areas.

NOTE. Cleaning requirements vary according to the local water conditions and individual user operation. Continuous check of the clarity of ice cubes and visual inspection of the water spraying parts before and after cleaning will indicate frequency and procedure to be followed in local areas.

4. With the ice machine and fan motor OFF on air cooled models, clean condenser using vacuum cleaner, whisk broom or non metallic brush taking care to do not damage both the condenser and ambient temperature sensors.
5. Check for water leaks and tighten drain line connections. Pour water down bin drain line to be sure that drain line is open and clear.
6. Check size, condition and texture of ice cubes. Perform adjustment of DIP SWITCH keys as required.
7. Check the ice level control sensor to test shut-off. Put your hand between the light source and the receiver so to cut off the light beam for at least one minutes. This should cause the ice maker to shut off and the light up of the 2nd LED (yellow light).

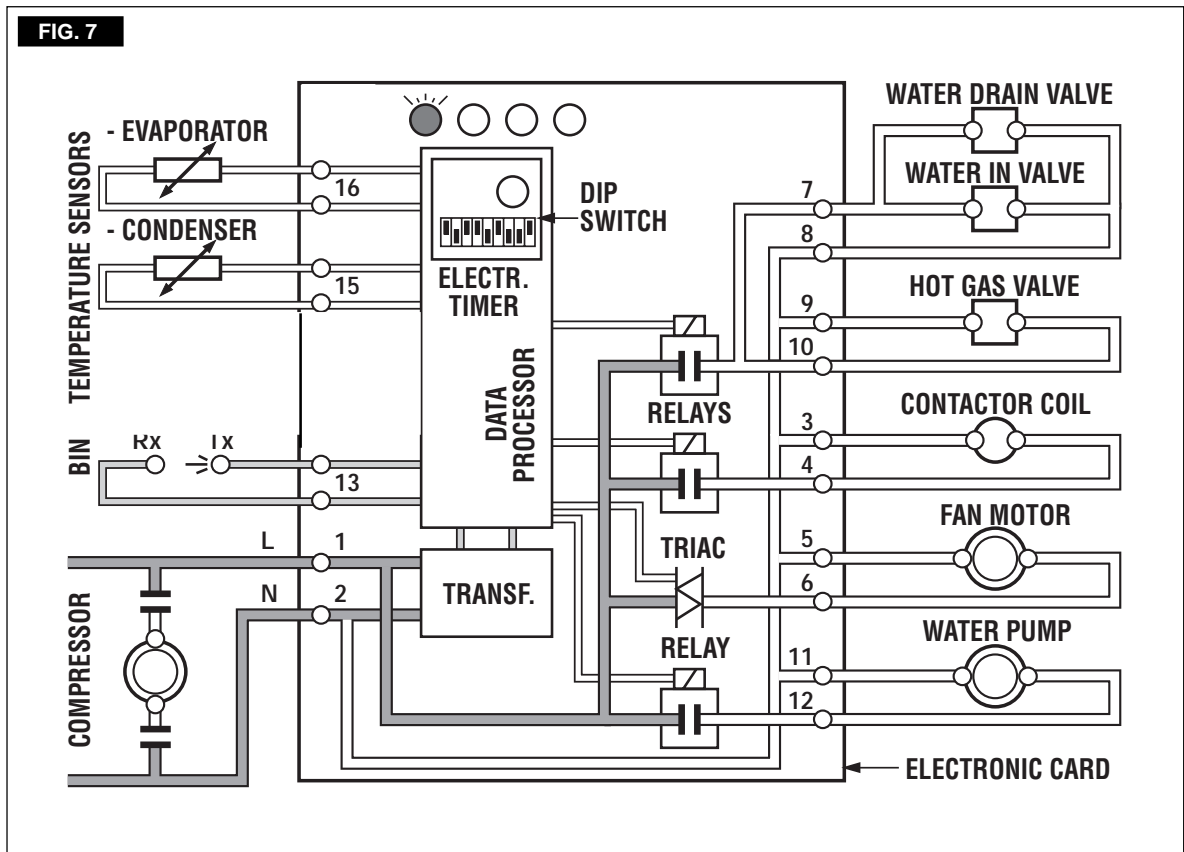

NOTE. Within few seconds after the removal of the hand from the Infrared sensing light the icemaker restarts in freezing cycle. The ice level control uses devices that sense light, therefore they must be kept clean enough so they can "see". Every month clean/wipe the sensing "eyes" with a clean soft cloth.

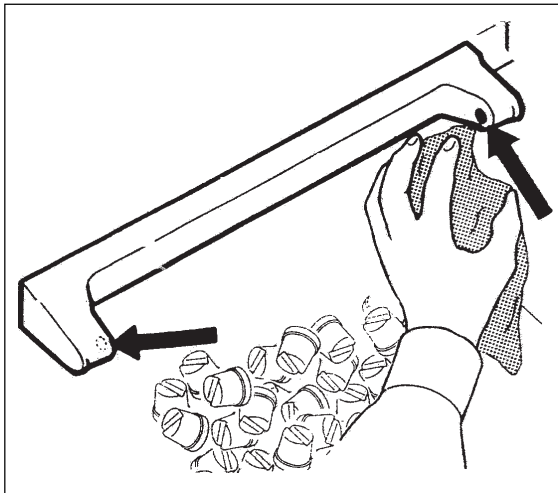

9. Check for refrigerant leaks.

C. CLEANING INSTRUCTIONS OF WATER SYSTEM

1. Remove the front and the top panels to gain access either to the control box and to the evaporator.
2. Wait till the end of defrost cycle then, unplug the machine from power line.

Cleaning

3. Prepare the cleaning solution by diluting in a plastic container two liters of warm water (45°-50°C) with a 0,2 liters of SCOTSMAN Ice Machine Cleaner.

WARNING. The SCOTSMAN Ice Machine Cleaner contains Phosphoric and Hydroxyacetic acids. These compounds are corrosive and may cause burns if swallowed, DO NOT induce vomiting. Give large amounts of water or milk. Call Physician immediately. In case of external contact flush with water. KEEP OUT OF THE REACH OF CHILDREN

4. Scoop out all the ice cubes stored into the bin in order to prevent them from being contaminated with the cleaning solution then flush out the water from the sump reservoir by removing the overflow stand-pipe.

FIG. 8

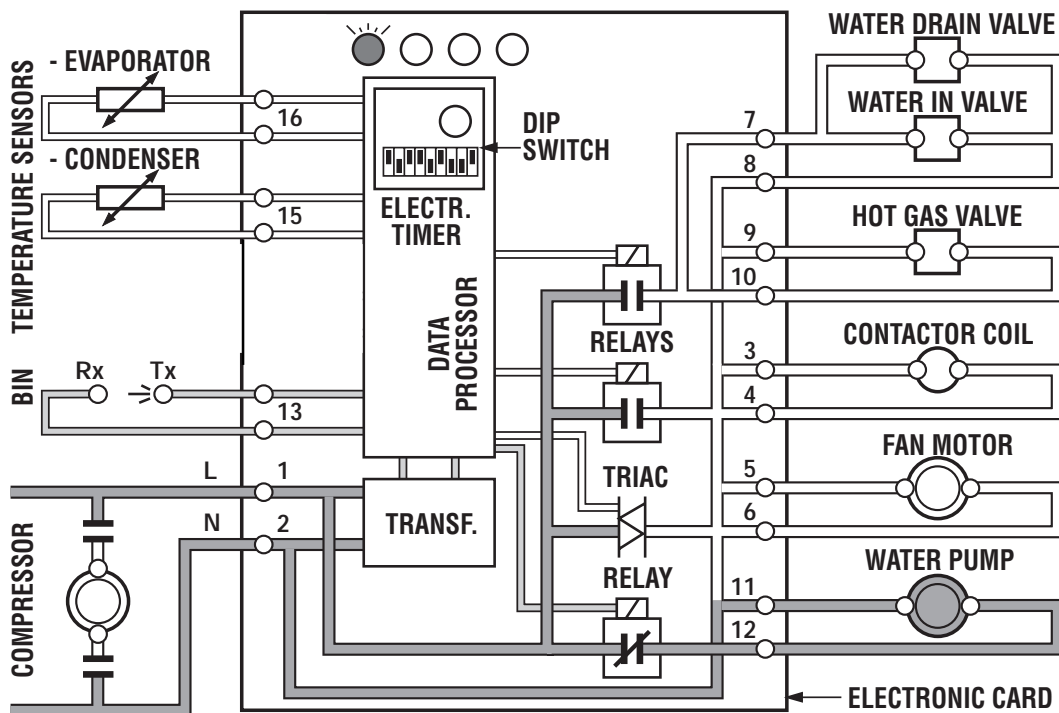

5. Remove the evaporator cover then slowly pour onto the evaporator platen the cleaning solution. With the help of a brush dissolve the most resistant and remote scale deposits in the platen.

6. Plug in again the machine and push the PUSH BUTTON for more then 2" and less then 5".

NOTE. *With the system in CLEANING/ RINSING mode the water pump is the only component in operation to circulate the cleaning solution in the entire water system.*

7. Let the unit to remain in the **CLEANING** mode for about 20 minutes then unplug again the machine.

8. Flush out the cleaning solution from the sump reservoir then pour onto the evaporator cavity two or three liters of clean potable water to rinse the mold cups and the platen. If necessary remove the water spray bar and spray jets to clean them separately.

9. Plug in again the machine and push the PUSH BUTTON as per item 6. The water pump is again in operation to circulate the water in order to rinse the entire water system.

10. Unplug the machine then flush out the rinsing water from the sump reservoir then plug in again.

NOTE. *The ice maker will perform the 5 minutes WATER FILLING phase i.e. the water inlet solenoid valve opens to allow the incoming water to rinse again the water system and to properly fill-up the sump reservoir for the next freezing cycle.*

Sanitation

NOTE. *Sanitation of the water system is recommended to be done **once a month.***

11. Prepare in a plastic container the sanitation solution as per manufacturer dilution using warm water (45-50 °C).

NOTE. *Never mix the cleaning with the sanitising solution.*

12. Follow the procedures as per cleaning (from item 4 to item 10) just shorting the operation of the water pump to 10 minutes.

13. Place again the evaporator cover and the unit service panels.

14. At completion of the freezing and harvest cycle make sure of proper texture and clearness of the ice cubes and that, they do not have any acid taste.

ATTENTION. *In case the ice cubes are cloudy, white and have an acid taste, melt them immediately by pouring on them some warm water. This to prevent that somebody could use them.*

15. Wipe clean and rinse the inner surfaces of the storage bin.

REMEMBER. *To prevent the accumulation of undesirable bacteria it is necessary to sanitize the interior of the storage bin with an anti-algae disinfectant solution every week.*